

SCULPTING THE “AESTHETICS OF AIR” FOR IMPROVED THERMAL COMFORT
TESTING A SKIP-STOP DOUBLE LOADED CORRIDOR SPATIAL
CONFIGURATION FOR NATURALLY VENTILATED HIGH-DENSITY BUILDINGS IN
HOT AND HUMID CLIMATES

A DARCH PROJECT SUBMITTED TO THE GRADUATE DIVISION OF THE
UNIVERSITY OF HAWAI‘I AT MĀNOA IN PARTIAL FULFILLMENT OF THE
REQUIREMENTS FOR THE DEGREE OF

DOCTOR OF ARCHITECTURE

IN

ARCHITECTURE

MAY 2016

By

Reece Bonilla

Doctorate Project Committee:

Wendy Meguro, Chairperson
Arthur Maskrey
Scott Inatsuka
Howard Wiig

Keywords: Skip-stop, double loaded corridor, natural ventilation, passive cooling, thermal comfort, hot and humid climates

TABLE OF CONTENTS

ACKNOWLEDGMENTS	iv
ABSTRACT	v
LIST OF FIGURES	vi
LIST OF ABBREVIATIONS	xi
PART I: BODY OF KNOWLEDGE	1
CHAPTER 1: Importance of High Rises in the Tropics.....	2
1.1 Population Growth, Scarcity of Land, the Rise of Urban Developments.....	2
1.2 Building Performance.....	3
1.3 Behavioral Dimensions on Thermal Comfort and Energy	6
CHAPTER 2: A Pre-Modern Model for Passive Design in the Tropics.....	7
2.1 Maximizing Natural Ventilation – Spatial Configuration.....	7
2.2 Minimizing Solar Heat Gain – Building Envelope.....	12
2.3 Reinterpreting the Pre-Modern Model for a New Tropical High Rise Model.....	15
CHAPTER 3: Design Considerations for Natural Ventilation in Urban Environments	16
3.1 Factors Relative to Thermal Comfort	16
3.2 Acoustics.....	22
3.3 Indoor Air Quality (IAQ).....	22
3.4 Airflow, Spatial Geometry, and Ventilation	24
3.5 Building Codes.....	28
3.6 Viability of Natural Ventilation in Honolulu.....	29
CHAPTER 4: Repercussions of Economic Preferences Relative to Tall Buildings.....	30
4.1 The Single and Double Loaded Corridor Spatial Configuration.....	30
4.2 The Glass Curtain Wall Building Envelope	33
4.3 The Viability of the Skip-Stop DLC and Balcony Design	34

CHAPTER 5: Unité d’Habitation by Le Corbusier.....	38
5.1 Marseilles Climate	38
5.2 Orientation	41
5.3 Spatial Geometry and Configuration	45
5.4 Building Envelope.....	48
PART II: RESEARCH PROJECT	51
CHAPTER 6: Research Objective	52
6.1 Analysis Plan.....	54
CHAPTER 7: Research Methodology	55
7.1 Measuring Thermal Comfort	55
7.2 Metric: Predicted Man Vote (PMV).....	57
7.3 Simulation Modeling.....	63
7.4 Software Tools.....	65
7.5 Location of Analysis.....	66
CHAPTER 8: Simulation Models and Inputs	72
8.1 Orientation and Immediate Location Relative to Sun and Wind.....	72
8.2 Double Loaded Corridor	78
8.3 Single Loaded Corridor.....	79
8.4 Skip-Stop Double Loaded Corridor.....	80
8.5 Building Envelope Design and Variables.....	81
CHAPTER 9: Sets of Analysis	86
9.1 Investigate the Effect of Spatial Configuration on Thermal Comfort	86
9.2 Investigate the Effect of Building Envelope Design on Thermal Comfort.....	86
9.3 Investigate the Effect of Ceiling Fans on Thermal Comfort	87
9.4 Visual Investigation of Air Flow and Speeds in Models (CFD)	88

CHAPTER 10: Results Breakdown.....	90
10.1 Bulk Air Flow.....	92
10.2 Computational Fluid Dynamics (CFD).....	108
PART III: RESEARCH SUMMARY	119
CHAPTER 11: Evaluation and Conclusions.....	120
11.1 Orientation to Sun and Wind.....	121
11.2 Window Openings and Ceiling Fans.....	125
11.3 Airflow relative to Spatial Configuration	129
11.4 Units of a Skip-Stop Double Loaded Corridor Configuration	132
CHAPTER 12: A Potential Model for Future Tropical Built Environments	135
12.1 Importance of an Adaptive Environment.....	135
12.2 Sculpting the Aesthetics of Air.....	139
APPENDICES	143
BIBLIOGRAPHY/REFERENCES	145

ACKNOWLEDGMENTS

Working on this D. Arch project was enjoyable as well as a challenging experience. In my years as a graduate student in the doctorate program, many people were instrumental directly or indirectly in shaping up my academic career. It was hardly possible for me to thrive in my doctoral work without precious support from many of these individuals to whom I'd like to thank.

My deepest gratitude goes first to Wendy Meguro, who introduced me to the wonderful world of natural ventilation. Her unwavering enthusiasm for natural ventilation kept me constantly engaged with my research. I would like to thank her for encouraging my research and for allowing me to grow as a researcher.

My appreciation also extends to Arthur Maskrey, Scott Inatsuka, and Howard Wiig for serving on my committee. Their contribution in knowledge and mentoring has been especially valuable, and their early insights launched the greater part of this D. Arch project. I am privileged for having such an amazing committee whose dedication and commitment was essential to the development of this project.

I express thanks to my fellow colleagues at Ferraro Choi and Associates for their guidance during my practicum semester. Special thanks to my significant other, Shannon, for being my bright spot when the world got crazy. Above all, I am indebted to my family, whose value to me only grows with age. Words cannot express how grateful I am for all of the sacrifices they've made on my behalf. They are my champions.

ABSTRACT

In an attempt to reduce building energy consumption and carbon emissions there is a growing worldwide interest in utilizing natural ventilation cooling in future high rise buildings. The use of natural ventilation cooling is not new to hot and humid regions of the world, yet this passive design principle found in tropical vernacular architecture is not found in many tall buildings in the tropics. The economically preferred double loaded corridor (DLC) spatial configuration generally associated with high rise models lack the ability to cross ventilate efficiently thereby surrendering to mechanical cooling for thermal comfort. The fundamental challenge is finding a solution that works well with cross ventilation and DLC configuration to improve thermal comfort and reduce building energy consumption.

The skip-stop spatial configuration found in Le Corbusier's Unité d'Habitation could be a solution in providing efficient cross ventilation for double loaded corridor designs and thus improve thermal comfort through passive cooling while providing efficient space planning for vertical development. The objective of this project was to investigate the ventilation performances and thermal comfort conditions of a proposed skip-stop double loaded corridor (SSDLC) spatial configuration in comparison to a DLC and single loaded corridor (SLC) configuration. Modifications to the building envelope and local air speeds via ceiling fans through parametric analyses were also tested to improve comfort in these naturally ventilated models. Estimated thermal comfort results in these models were not seen as absolute but relative to the conditions being investigated.

The research evaluates each model in Honolulu's climate. Thermal comfort and air flow analysis was conducted using bulk air flow and computational fluid dynamic (CFD) modeling through the Integrated Environmental Solutions (IES) Virtual Environment software. The Predicted Mean Vote (PMV) model was used as a metric to determine acceptable thermal comfort. The resulting research is beneficial for architects practicing in Hawaii and other major tropical cities around the world, as it provides a passive and economic solution to the cross ventilation and double loaded corridor dilemma in tall building designs, not to mention the energy savings that could potentially come out of utilizing such model in a hot and humid climate.

LIST OF FIGURES

Figure 1. Tropical regions of the world and projected population growth.....	2
Figure 2. Hawaii's crude oil prices in comparison to the nation's average.....	4
Figure 3. Hawaii's petroleum dependency in comparison to other energy sources	5
Figure 4. The effects of ventilation with an elongated floor plan	8
Figure 5. The effects of building layouts and orientations relative to prevailing winds	9
Figure 6. Staggered spatial configuration found in a traditional Malay house	10
Figure 7. The Met by WOHA, staggered spatial configuration.....	11
Figure 8. The Malay house building envelope	13
Figure 9. Metabolic rates for typical tasks	17
Figure 10. Levels of clothing insulation	18
Figure 11. Psychometric chart illustrating the potential for natural ventilation	21
Figure 12. Honolulu's ambient air quality as measured by the NAAQS	24
Figure 13. Space planning efficiency of the (a) double loaded corridor and (b) open floor plan	26
Figure 14. Air flow relative to the section perspective of a (top) double loaded corridor and (bottom) single loaded corridor spatial configurations	31
Figure 15. Traditional double and single loaded corridor spatial configuration.....	32
Figure 16. Wind patterns around various building forms with sealed building envelopes ..	33
Figure 17. Air flow relative to the section perspective of a skip-stop double loaded corridor spatial configuration.....	35
Figure 18. Skip-stop spatial configuration with other various types of apartment units in a single building accommodating a wide variety of user groups	36
Figure 19. Day lighting effects of various apartment unit designs	37
Figure 20. Marseille, France psychometric charts	39
Figure 21. Wind rose	40

Figure 22. The points graphed on this psychrometric chart represent hourly conditions of Marseilles, France	41
Figure 23. Marseilles, France: sun path diagram	42
Figure 24. Typical Unité d’Habitation building floor plan.....	44
Figure 25. Unité d’Habitation staggered spatial arrangement of A and B type apartments.	46
Figure 26. Sections of two common apartment units in the Unité d’Habitation building inspired by wine bottle racks.....	47
Figure 27. Floor plan of two common apartment units in Unité d’Habitation	47
Figure 28. Unité d’Habitation building envelope design	48
Figure 29. Unité d’Habitation building envelope design	50
Figure 30. Le Corbusier’s Unité d’Habitation skip-stop double loaded corridor spatial configuration inspired by a “wine bottle rack”	53
Figure 31. The six main factors in thermal comfort	57
Figure 32. Hourly conditions are calculated producing a number that falls on the predicted mean vote (PMV) thermal sensation scale.....	59
Figure 33. Predicted Mean Vote relative to Predicted Percentage Dissatisfied	60
Figure 34. Thermal comfort zone in air conditioned spaces versus naturally ventilated spaces relative to thermal sensations of the predicted mean vote model.....	61
Figure 35. Estimated predicted mean vote (PMV) thermal comfort zone.....	63
Figure 36. Types of modeling relative to design processes	64
Figure 37. Software used for this analysis.	66
Figure 38. Honolulu average monthly environmental conditions.....	67
Figure 39. Honolulu’s annual weather data represented on a psychrometric chart	68
Figure 40. Energy consumption in Hawaii (2013).....	69
Figure 41. Psychrometric Chart of Honolulu’s climate hourly conditions.....	71
Figure 42. Honolulu’s sun path diagram	73

Figure 43. Double loaded corridor building model and orientation.....	74
Figure 44. Single loaded corridor building model and orientation.....	75
Figure 45. Skip stop double loaded corridor building model and orientation	75
Figure 46. Wind rose of Honolulu.....	77
Figure 47. Double Loaded Corridor (DLC) model developed for the analyses.....	79
Figure 48. Single Loaded Corridor (SLC) model developed for the analyses	80
Figure 49. Unité d'Habitation inspired Skip-Stop Double Loaded Corridor (SSDLC) model developed for the analyses	81
Figure 50. Building envelope design and model inputs for each configuration.....	82
Figure 51. Projection factors tested on the single loaded corridor (SLC) model.	83
Figure 52. Window opening areas (highlighted) tested on the single loaded corridor (SLC) model.....	84
Figure 53. Increased local air speed relative to perceived comfort.....	85
Figure 54. Adaptive behavior on thermal comfort using the elements of the built environment	87
Figure 55. Thermal comfort zone expanded with introduction to increased local air speed on the psychrometric chart	88
Figure 56. Predicted air flow in each tested spatial configuration model.....	89
Figure 57. A snapshot of the spatial configuration models tested	91
Figure 58. A snapshot of model inputs for all three spatial configurations.....	92
Figure 59. Estimated predicted mean vote (PMV) thermal comfort zone (-1.5<Comfort<+1.5) used for the analysis in determining acceptable thermal comfort	93
Figure 60. Models tested for the baseline analysis.....	94
Figure 61. Total annual hours above the predicted mean vote (PMV) upper threshold of +1.5 for all models.....	95
Figure 62. Thermal sensation results of each spatial configuration	96
Figure 63. Models tested for the shading projection factor (PF) parametric analysis	97

Figure 64. Effects of shading on thermal comfort	98
Figure 65. Effects of shading on thermal comfort	99
Figure 66. Models tested for window opening area parametric analysis	100
Figure 67. Effects of window opening area on thermal comfort	101
Figure 68. Models tested for local air speed parametric analysis.....	102
Figure 69. Effects of local air speed on thermal comfort.....	103
Figure 70. SSDLC models tested for the orientation analysis.....	104
Figure 71. Skip-top double loaded corridor orientation results.....	106
Figure 72. Orientation comparison of the skip-stop double loaded corridor with various window openings relative to local air speeds	107
Figure 73. Beaufort scale and effects felt on land.....	110
Figure 74. Double loaded corridor CFD results on August 26 at 8:00pm	112
Figure 75. Single loaded corridor CFD results on August 26 at 8:00pm.....	114
Figure 76. Skip-Stop Double Loaded Corridor (0°) CFD Results on August 26 at 8:00pm ..	116
Figure 77. Skip-Stop Double Loaded Corridor (180°) CFD Results on August 26 at 8:00pm	118
Figure 78. Comparison of the prescribed comfort zone in air conditioned spaces (-0.5<comfort<+0.5) versus the estimated thermal comfort zone in naturally ventilated spaces (-1.5<comfort<+1.5)	121
Figure 79. Orientation of each spatial configuration model relative to the sun exposure.	123
Figure 80. By increasing local air speed to 2.33 ft/s in the single loaded corridor model.	126
Figure 81. Parametric results - window opening area relative to local air speeds.....	127
Figure 82. Increased air speeds on perceived thermal comfort.....	128
Figure 83. Side-by-side examination of air flow patterns relative to each model.....	130
Figure 84. Skip-stop spatial configuration with other various types of apartment units in a single building accommodating a wide variety of user groups	131

Figure 85. CFD comparison of the SSDLC model in two orientations.....133

Figure 86. Adaptive behavior – switching on a fan, opening a window, shading a window
– for thermal comfort in response to hot and humid conditions.....136

Figure 87. Psychrometric Chart of Honolulu’s climate hourly conditions.....138

Figure 89. Optimal spatial configuration and building envelope model for natural
ventilation in Honolulu based on research findings.....141

LIST OF ABBREVIATIONS

ADA	Americans with Disabilities Act
ASHRAE	American Society of Heating, Refrigeration, and Air-Conditioning Engineers
ATC	Adaptive Thermal Comfort
ASTM	American Society for Testing and Materials
CFD	Computational Fluid Dynamics
DBEDT	Department of Business, Economic, Development, and Tourism
DLC	Double Loaded Corridor
DOE	U.S. Department of Energy
EPA	Environmental Protection Agency
HEC	Hawaii Energy Code
HVAC	Heating, Ventilation, and Air-Conditioning
IAQ	Indoor Air Quality
IBC	International Building Code
IECC	International Energy Conservation Code
kWh	Kilowatt-hour
MRT	Mean Radiant Temperature
NAAQS	National Ambient Air Quality Standards
PF	Projection Factor
PIT	Point in Time
PMV	Predicted Mean Vote
PPD	Percent of Persons Dissatisfied
SBS	Sick Building Syndrome
SET	Standard Effective Temperature
SHGC	Solar Heat Gain Coefficient
SLC	Single Loaded Corridor
SSDLC	Skip-Stop Double Loaded Corridor
TMY	Typical Meteorological Year
VRP	Ventilation Rate Procedure
WPF	Window-to-Floor Ratio

PART I
BODY OF KNOWLEDGE

CHAPTER 1

Importance of High Rises in the Tropics

1.1 Population Growth, Scarcity of Land, the Rise of Urban Developments

According to the State of the Tropics 2014 Report the world can expect significant population and economic growth in the tropics in the next few decades.¹ Currently home to 40% of the world's population, the rate of economic growth of these tropical regions is 20% faster than the rest of the world. By 2050 it is expected that half of the world's population will reside in the tropics. With these projections greater pressure is being put on the natural environment as the issue of land scarcity becomes more prominent especially in the oceanic region of the world.



Figure 1. Tropical regions of the world and projected population growth relative to location.

Source: State of the Tropics 2014 Report

¹ (Tropics 2014)

Recent projections of population growth have had many cities consider the viability of vertical development versus horizontal development or urban-sprawl. The concept of urban sprawl is becoming less favored due its energy inefficiency and environmental impact. Urban sprawl developments, due to its horizontal manner, require a great deal of energy to transport services such as water and electricity to housing and commercial buildings in rural environments. Along with the issue of land scarcity, these concerns are prompting urban development in many tropical cities as 45% of the tropic world population is now living in cities as of 2010.² As a result, high rises (also have been called vertical cities) are increasing in demand as those provide high-density housing and businesses in a vertical manner all within a smaller land area.³

Hawaii, specifically the city of Honolulu on the island of Oahu, has already begun looking into the concept of vertical cities such as mix-used developments as a means to accommodate recent projections of population growth expected in the next few decades. A recent report indicates that Hawaii is expected to have a population growth of 1% (about 14,000 residents) annually state-wide with increasing demands for jobs to follow.⁴ With the issue of land scarcity on the island of Oahu, landowners and state agencies are continuously working together looking at high rise mix-use development as a solution to these rising demands. Such recent developments have begun to take place in Kaka’ako, currently an industrial district with many low-rise shops and small businesses. Envisioned to be a “third city” on the island of Oahu, the urban development in Kaka’ako is expected to become a live-work-play environment with many high-rise buildings for condos, businesses, and entertainment.⁵

1.2 Building Performance

High rise building typologies are known for their high energy consumption as a result of using large Heating, Ventilation, and Air-Conditioning (HVAC) systems in providing thermal comfort. Chiller Energy Management System Engineering (CEMSE) in Malaysia reported that air conditioning accounts for 40-60% of energy consumption in most buildings residing in the tropics.⁶ High air temperature and humid conditions

² (Tropics 2014)

³ (Jatupatwarangkul 2012)

⁴ (Shimaogawa 2014)

⁵ (Creamer 2012)

⁶ (Instruments 2015)

associated with the tropics put greater energy demands on HVAC systems to cool and remove humidity. Although there has been progress in making air conditioning systems more energy efficient in the past decade there is still the issue of high energy costs that many developing tropical regions are faced with relative to the nation's average.



Figure 2. Hawaii's crude oil prices in comparison to the nation's average.

Source: United States Energy Information Administration (EIA)

Due to lack of fossil fuel resources as well as high energy costs of petroleum imports, many oceanic tropical regions, such as Hawaii, have invested in renewable energy like wind and solar. However, the energy outputs of these systems are still minor, only contributing 13% of the overall generation as of 2013.⁷ It is clear that Hawaii is still highly dependent on petroleum-based energy. In an attempt to aid in reducing building energy consumption and thus reducing the need for petroleum-based energy, the architecture communities of many tropical cities are beginning to consider a more passive approach to building design utilizing vernacular principles like natural ventilation cooling. Natural ventilation cooling reduces the need for mechanical cooling via air conditioning, therefore lowering building energy consumption and costs.

⁷ (Shear 2014)



Figure 3. Hawaii's petroleum dependency in comparison to other energy sources.

Source: United States Energy Information Administration

Ken Yeang, a Malaysian architect known for his design approach on sustainable/bioclimate/ecological high rise designs, believes air conditioning cannot be completely dismissed from modern tropical architecture but rather architects should look at the efficiency of tropical vernacular design to reduce the need for mechanical cooling and ventilation that lead to high building energy consumption.⁸ He states that it is possible to significantly decrease building energy consumption by utilizing natural energies such as wind and better integration of building systems. Natural ventilation “has a significant and growing role in delivering more sustainable and comfortable buildings” in the urban environment.⁹ It is important to study the passive design principles found in tropical vernacular design providing insight and basis to developing a new sustainable high rise model for improved thermal comfort in hot and humid climates.

⁸ (Yeang 2008)

⁹ (Twinn 2011)

1.3 Behavioral Dimensions on Thermal Comfort and Energy

There is evidence from field studies that suggest overcooled buildings in the tropics are “not consequence of occupant preference but more like an outcome of HVAC system design and operation.”¹⁰ Occupants are forced to adapt to these overcooled conditions with additional clothing. However, as many have pointed out, this adaptation cannot be seen as an “effective mitigating strategy for cold thermal discomfort.”¹¹ Instead, occupant control of their microenvironment with “separate strategies for ventilation and cooling” could potentially offer a better solution to enhance thermal comfort while reducing building energy consumption at the same time.

Intergovernmental Panel on Climate Change (IPCC) has made it clear that “the buildings sector presents the biggest potential for deep and fast CO₂ emission reductions on a cost-effective basis.” However, some have argued that this assessment was “premised exclusively on technical (engineering) measures, but ignored completely the behavioral and lifestyle dimensions of energy consumption in the buildings sector.”¹² Behavioral change in buildings, such as manipulation of window openings and local air speeds via ceiling fans, can have a great effect on not only thermal comfort in naturally ventilated spaces but in energy efficiency and greenhouse gas (GHG) emission reductions. Many believe that “building designers are beginning to shift their attention to how they can widen the range of opportunities available in a building to provide comfort for occupants. This in turn has re-awakened an interest in the role of natural ventilation in the provision of comfort.”¹³

¹⁰ (Sekhar 2015)

¹¹ Ibid

¹² (de Dear, Cândido, et al. 2010)

¹³ Ibid

CHAPTER 2

A Pre-Modern Model for Passive Design in the Tropics

What does a high rise building look like in the tropics? Most importantly, how does it perform efficiently in hot-humid conditions associated with the tropics? Before answering these daunting questions the passive design principles of the basic design model found in tropical climates must first be understood. Examining pre-modern passive design principles found in tropical vernacular architecture provides a foundation for innovation. The fundamental challenge is how to reinterpret these passive design principles for the modern day high rise building. On the contrary, current non-passive models typically used for modern high rise designs should also be understood in comparison to the pre-modern models as to demonstrate the effects of each on natural ventilation and thermal comfort relative to each other.

Tropical vernacular designs differ from region to region – geography, local wind pattern, material sources, etc. – despite all of them residing in hot-humid climates. However, a pattern is revealed in many of these passive designs that follow two basic principles – (1) maximize natural ventilation and (2) minimize solar heat gain as much as possible.¹⁴ A building in a hot and humid condition must consider several elements of design such as orientation relative to sun and wind, spatial geometry, and the building envelope. These factors greatly affect a building's ability to cross ventilate and receive solar radiation therefore being a significant importance to occupant thermal comfort when designing for naturally ventilated spaces. One most notable design of the tropics that greatly considers these factors in relation to occupant thermal comfort is the traditional Malay house of Malaysia.

2.1 Maximizing Natural Ventilation – Spatial Configuration

Orientation and spatial geometry are crucial to the success of cross ventilation as well as minimizing solar radiation for passive cooling in the tropics. The Malay house takes on several different spatial geometries, one of them being an elongated floor plan with little or no internal partitions. This spatial layout is a popular design pattern found in tropical architecture. Longer facades face towards prevailing winds allowing efficient airflow with minimal resistance. Inlets and outlets are abundant on the longer facing

¹⁴ (Simons, et al. 2014)

facades to allow air to flow through the building while the shorter sides are opaque reducing low sun exposures from the east in the early morning and from the west in the late afternoon.



Figure 4. The effects of ventilation with an elongated floor plan compared to a more complex spatial configuration with internal partitions traditionally found in many modern day homes.

Source: *The Malay House: Rediscovering Malaysia's Indigenous Shelter System*, Yuan

Another reoccurring pattern found in tropical vernacular designs is the use of staggered spatial geometry and configurations, both externally and internally. This is more clearly illustrated in a spatial organization of a traditional Malay house. The Malay house defines its internal spaces in a horizontal manner through staggered floor level changes rather than vertical walls. In conjunction with high ceilings these staggered floor levels have different levels of ventilation depending on their usage (purpose) and position relative to the ground and wind direction.¹⁵ The basic overall design strategy was to allow wind to flow freely to maximize passive cooling via cross ventilation. Cross or wind-driven ventilation uses pressure differences generated by the building geometry and envelope to drive wind through (or across) a building.¹⁶ This was further enhanced by providing inlets and outlets for each occupied space with the help of a staggered spatial geometry. On a larger scale, individual homes were also oriented in a staggered arrangement as to allow for efficient cross ventilation between a series of buildings.

¹⁵ (Yuan 1987)

¹⁶ (Baker 2014)



Figure 5. The effects of building layouts and orientations relative to prevailing winds in comparison to what is seen in modern urban environments.

Source: *The Malay House: Rediscovering Malaysia's Indigenous Shelter System*, Yuan

Floors are raised as to not only provide protection from flooding and critters but to enhance ventilation and passive cooling. Such design method directly correlates with the vertical wind gradient, where higher elevations would receive higher wind velocities.¹⁷ A high ceiling with open roof vents use stack or buoyancy-driven ventilation to exhaust internal heat gains produced by the occupants inside. Stack ventilation is driven by air buoyancy where lower openings in the building façade allow cool air to enter while higher openings such as the roof vents allow for warmer air to exit.¹⁸ This type of ventilation is not as effective as cross ventilation but can be useful during times with little to no wind for wind-driven ventilation. Both wind-driven and buoyancy-driven ventilation can occur simultaneously having a greater cooling effect.

¹⁷ (Yuan 1987)

¹⁸ (Grondzik, et al. 2010)



Figure 6. Staggered spatial configuration found in a traditional Malay house. Spaces are divided using various levels (horizontal) rather than vertical partitions found in modern day homes.

Source: *The Malay House: Rediscovering Malaysia's Indigenous Shelter System*, pg. 75, Yuan

This concept of linear and staggered spatial configurations is not entirely new to the modern world as there are a few successful examples of cross ventilated residential high rises in tropical regions like the Met condominium by WOHA in Bangkok. The Met utilizes a staggered spatial geometry that allows each apartment to have openings on both windward (high pressure façade) and leeward (low pressure façade) sides to allow for pressure differences to occur and thus effectively provide cross ventilation.¹⁹ Many will find this unique staggered spatial configuration to be a great example of

¹⁹ (The Met/WOHA 2015)

reinterpreting pre-modern passive design principles as it provides a solution for efficient cross ventilation in a high rise building residing in the tropics.



Figure 7. The Met by WOHA, staggered spatial configuration for effective cross ventilation in each apartment unit.

Source: *The Met / WOHA*, Arch Daily

Designed from temperate models, most tall buildings have double loaded corridors (DLC) spatial configurations where units are placed alongside a central access corridor. This spatial geometry simply does not work with cross ventilation because internal partitions such as the access corridor act as a barrier to air flow. As a result, units are subjected to single-sided ventilation which is moderately effective compared to the potential thermal comfort benefits of cross ventilation. Corner or end units of a high-

density building are an exception as it provides two facades for window openings.²⁰ Single-sided ventilation, with restricted wall opening area and depth, simply does not provide enough “ventilation volume for free cooling.”²¹ These spaces thereby surrender to air conditioning for thermal comfort due to their inability to cross ventilate.²²

2.2 Minimizing Solar Heat Gain – Building Envelope

One of the main design characteristics of tropical vernacular architecture is the building envelope’s ability to adapt to the local climate and environmental conditions. Because outdoor conditions in tropical climates are close to the desired indoor conditions the building envelope begins as an open frame structure where the skin is designed to be flexible as to control the incoming environmental forces like sun and wind.²³ The building envelope can be modified as to control ventilation for passive cooling and removal of internal heat gain. Most importantly, adequate shading is provided around the building’s exterior to prevent penetration from direct sun light thereby minimizing heat gain as much as possible. The building envelope design of the traditional Malay house is a perfect example of adapting to the local hot-humid climate.

Elongated spatial configurations aid in the effectiveness of cross ventilation and its orientation to the sun plays a vital role in receiving solar radiation. In this configuration shorter opaque facades are orient towards the “direction of the strongest solar radiation” such as East and West.²⁴ This reduces low sun exposures that occur during the early morning and late afternoon that would otherwise contribute to significant heat gain and result in thermal discomfort. It is important to note that this may not always play out with the direction of prevailing winds if they are coming from east or west. In any case, architects must consider microclimates as a design driver for naturally ventilated spaces attempting to maximize ventilation while minimizing heat gain at the same time.

²⁰ (Kim, et al. 2008)

²¹ Ibid

²² Ibid

²³ (Grondzik, et al. 2010)

²⁴ Ibid



Figure 8. The Malay house building envelope and its ability to adapt to the local climate.

Source: *The Malay House: Rediscovering Malaysia's Indigenous Shelter System*, pg. 75, Yuan

Christian Norberg-Schulz, a Norwegian architect and theorist, suggests the function of a building envelope can be better understood as a *connector*, *filter*, *barrier*, or *switch* in regards to the exchanges of energies (sun, wind, etc.) between the outdoor and indoor environments.²⁵ A building envelope can have more than one of these characteristics at the same time and it is the combination of these characteristics that dictate the performance of a building situated in a particular climate. An opaque wall is a *filter* due to its thermal transfer properties from exterior to interior and vice versa yet it acts as a *barrier* to light and wind. An operable window acts as a *switch* allowing control over incoming forces like wind but glazing acts as a *connector* to light.

Switches allow the building envelope to respond to the external climatic conditions, building and occupant needs, and available resources.²⁶ However the efficiency of switches is greatly dependent on those that control it, the occupants. A great deal of knowledge and occupant cooperation is required to ensure optimal

²⁵ (Norberg-Schulz 1968)

²⁶ (Grondzik, et al. 2010)

performance of these types of building envelopes and building energy consumption as a whole. A tropical vernacular building envelope acts basically as a giant *switch* as in most cases will utilize many operable windows and screens for occupant control over their indoor environment. Yet the building envelope of many modern tropical tall buildings do not function as a *switch*, but rather a *connector* to light, heat and a *barrier* to wind as seen prominent in the temperate high rise model. The temperate model works great in the climate it originated from but not well in the tropics where opposite conditions are more desirable – maximizing ventilation and minimizing heat gain.

The building envelope of typical high rise designs mainly incorporate aluminum glazed curtain wall systems – a *connector* to heat and a *barrier* to natural ventilation for passive cooling.²⁷ Added with little or no external shading, heat gain from direct sunlight is one of many issues associated with high energy demands for mechanical cooling in the tropics as a study shows that “heat gain through the exterior window accounts for 25-28% of the total heat gain.”²⁸ Current building envelope designs of tall buildings have restricted opening area and depth due to safety issues.²⁹ These restrictions have shown to hinder the performance of naturally ventilated tall buildings as they simply do not provide enough airflow for effective passive cooling. A survey shows that occupants of these types of restricted naturally ventilated buildings feel a lack of ventilation where they cannot “feel air flow even when they open a window.”³⁰ As a result, mechanical cooling and ventilation is used to provide thermal comfort.

Shading can have a positive effect on thermal comfort as can be seen prevalent in pre-modern models as well as recent reports and studies on existing buildings.³¹ Lack of external shading devices further increase energy loads required to remove heat from internal spaces. Interior shading devices to some degree aid in the prevention of direct sun light but heat gain is still highly prominent as the air within the space between glazing and internal shading device is heated up. With a non-porous building envelope, the hot air is circulated within the room adding more discomfort for occupants. As a result, higher energy loads are put on HVAC systems to cool the heated air inside the occupied spaces.

²⁷ (Kim, et al. 2008)

²⁸ (Al-Tamimi, Fadzil and Harun 2011)

²⁹ (Kim, et al. 2008)

³⁰ (Cho, et al. 2007)

³¹ (Chenvidyakarn 2007)

The building envelope of commercial or office building typologies are designed to be sealed as it differs from residential typologies. There are many reasons to this, one being greater occupant load per square foot.³² For example, a 5-person family living in a 2,000 SQFT residence versus 25 employees working in a 2,000 SQFT office space. With higher occupancy loads as well as the heavy use of computer equipment found in the modern day office space creates greater internal heat gain that natural ventilation cannot simply remove by itself thus requiring mechanical energy via large HVAC systems. These systems work best with a sealed building envelope and have become part of the basic model for many office building typologies.

With fewer window openings per square foot of space, such as deep open floor plan designs, decreases the efficiency and viability of naturally ventilated building façades for these spatial typologies. In contrast, the building envelope of residential high rises have the opportunity to benefit from natural ventilation cooling as the occupant and internal heat loads are far less than commercial and office typologies. There is also greater control of the building envelope as occupants are able to freely regulate their personal thermal comfort within their own individual apartment units.

2.3 Reinterpreting the Pre-Modern Model for a New Tropical High Rise Model

A new model is needed for future high rise designs in the tropics, one that considers orientation relative to sun and wind but most importantly spatial geometry and the building envelope that maximizes ventilation and minimizes heat gain at the same time. Le Corbusier once said, "Vernacular is designed by immediate response and has had the fortunate ability to be modified according to suit the occupant's thermal needs, resulting in practical and non-stylistic buildings."³³ He also quoted, "Today, great architecture is also designed by instinct and... in unison with nature. The high technology and complicated materialism is just an enormous mantle, which clothes the idea. Underneath, the instinctive solution is still there." Innovation is built on tradition. The challenge is how these passive design principles and features can best be reinterpreted for modern tall buildings rather than directly mimicked.

³² (Levine and Ürge-Vorsatz 2014)

³³ (Bezemer 2008)

CHAPTER 3

Design Considerations for Natural Ventilation in Urban Environments

Understanding passive features found in pre-modern tropical vernacular architecture provide a foundation to designing naturally ventilated tall buildings. However, there are more to these basic design principles that should be considered, some of which directly deal with buildings situated in an urban setting. Pre-modern designs are found in rural and/or well vegetated environments. In contrast, tall buildings are generally constructed within urban environments surrounded by other tall buildings with little surrounding vegetation. Designing for natural ventilation in an urban setting requires looking into other various factors that limit pre-modern passive methods.

3.1 Factors Relative to Thermal Comfort

As with any building design occupant comfort and well-being is very important. There are risks relying purely on natural ventilation for passive cooling; risks that could deeply affect occupant thermal comfort if not done right.³⁴ These risks that lead most building designs to include infrastructure such as Heating, Ventilation, and Air-Conditioning (HVAC) systems which is more reliable in providing regulated air flow, temperature, and humidity for sufficient indoor air quality (IAQ) and occupant comfort. However, if these systems are not properly maintained the effects of air conditioning may prove to be more harmful to occupants than originally intended, not to mention high energy consumption that come with using these systems in high-density buildings. Natural ventilation decreases the need for conventional cooling via HVAC systems thus reducing building energy consumption and improving occupant health and comfort at the same time.

Thermal comfort as defined by ASHRAE is “the condition of mind which expresses satisfaction with the thermal environment.”³⁵ Thermal comfort is affected by three categories of factors – individual, environmental, and psychological.³⁶ Individual or personal factors are metabolic rate (measured in MET) and clothing insulation (measured in CLO).³⁷ Metabolism rate is the rate at which we as living organisms generate heat and

³⁴ (Meguro 2005)

³⁵ (ASHRAE 2013)

³⁶ (Grondzik, et al. 2010)

³⁷ Ibid

is dependent on one's level of activity, whether being at rest, walking, driving, exercising, etc. Clothing insulation acts as the body's second skin and thus the selection of clothing in a particular environment can affect the overall thermal comfort of an individual as well as provide occupants the ability to adjust to the changing conditions in the natural environment.

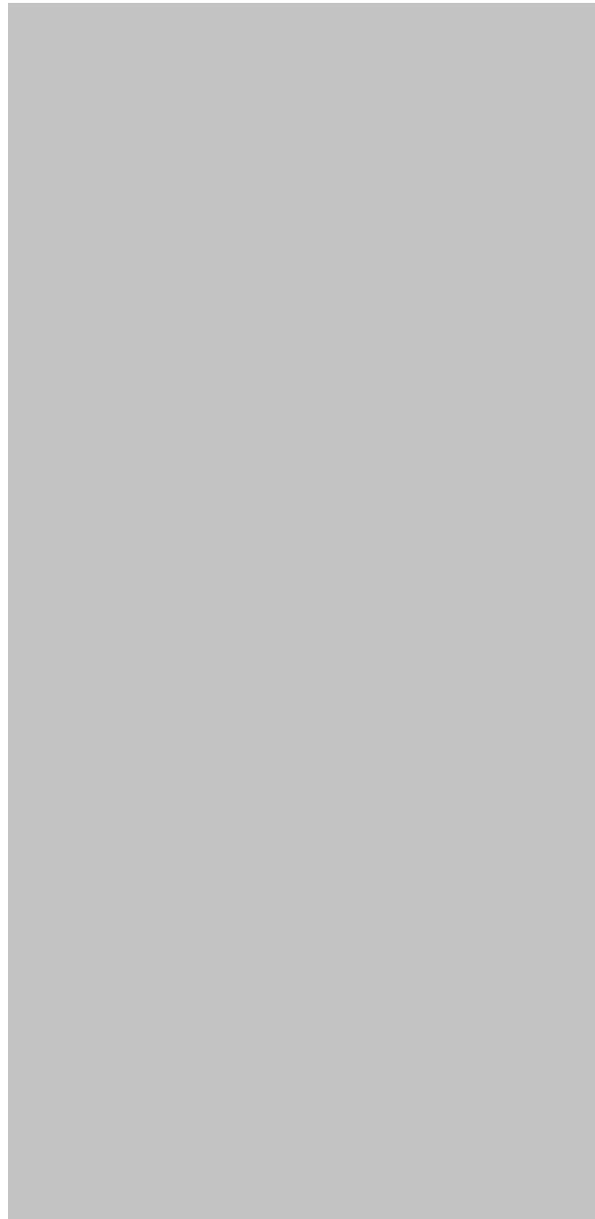

Figure 9. Metabolic rates for typical tasks

Source: ASHRAE Handbook - Fundamentals

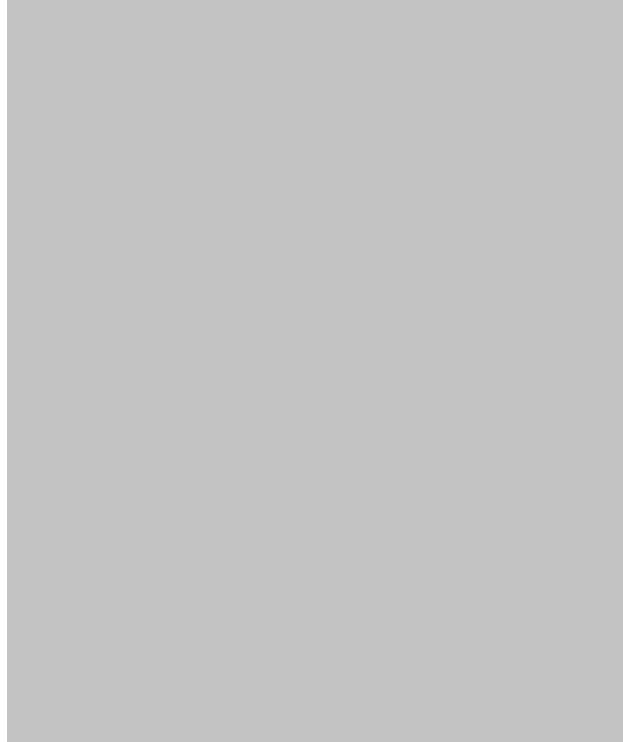

Figure 10. Levels of clothing insulation
Source: ASHRAE Handbook - Fundamentals

Environmental factors include air temperature (°F), radiant temperature (°F), air velocity (ft/s), and relative humidity (%). These factors differ in regions and climates. A naturally ventilated building must account for location relative to climate simply because the external environment will have a direct affect with the internal environment. The building envelope is responsive to the climatic conditions to control incoming external forces like sun and wind as they fluctuate throughout the day, seasons, and year. In addition to a well-designed building envelope, occupants of naturally ventilated spaces must be knowledgeable of their adaptive building envelope to optimize indoor thermal comfort.

Psychological factors are difficult to measure in comparison to the numerical individual and environmental factors. They include color, texture, sound, light, movement, and aroma as defined by ASHRAE. As a result, designers often overlook these influences on occupant comfort.³⁸ However, these factors are part of the main

³⁸ (Grondzik, et al. 2010)

issues when designing naturally ventilated buildings in an urban setting as will be discussed later in this chapter. The combination of these three main factors gauges one's personal sensation on thermal comfort.

Achieving thermal comfort through passive measures in the tropics is challenging. High thermal conditions and relative humidity plays a large role in the overall thermal comfort of an individual.³⁹ In scientific terms, the body's ability in losing heat – cooling through perspiration – is greatly decreased as the over saturated air typically found in the tropics can hinder the evaporation of sweat. This leads to unsatisfied comfort as one will continue to experience the hot and “sticky” feeling associated with hot and humid climates. Natural ventilation cooling is an effective passive solution to aid in thermal comfort in the tropics as higher air speed is used to offset high temperatures and increase evaporation of sweat.⁴⁰

“Air temperature is often taken as the main design parameter for thermal comfort.”⁴¹ A survey suggest that air temperature alone “is a good indicator of thermal comfort”⁴² Even with higher outdoor conditions as experienced in the tropics this study has shown that occupants in naturally ventilated buildings “achieved comfort compared to the recommendations of international standards such as the ISO 7730 and ASHRAE.”⁴³ Other studies have been conducted in attempt to further analyze the effectiveness of natural ventilation in buildings in relation to high outdoor air temperatures and relative humidity. The results indicate that relative humidity has an effect on overall comfort in naturally ventilated buildings with outdoor temperatures between 68-86°F.⁴⁴

Thermal comfort in the tropics can be achieved with higher air temperature and humidity because of occupant's acclimatization. Acclimatization refers to the “long-term responses of an organism to changes in its environment.”⁴⁵ This was further investigated in a study where those occupying a naturally ventilated building were found to be more tolerable to temperature swings than those occupying fully air conditioned

³⁹ (Givoni 1998)

⁴⁰ (Grondzik, et al. 2010)

⁴¹ Ibid

⁴² (Heidari and Sharples 2002)

⁴³ Ibid

⁴⁴ (Nicol 2004)

⁴⁵ (Britannica 2015)

spaces.⁴⁶ Researchers have linked psychological factors to these results as occupants made behavior changes to adapt to the changing conditions such as clothing insulation, open/close windows, and indoor local air speeds via interior ceiling fans. By altering these environmental and individual variables expands the thermal comfort threshold and zone.⁴⁷

The psychrometric chart (Figure 11) illustrates the expanded comfort zone with the introduction of natural ventilation in Honolulu's climate relative to the standard comfort zone. The standard comfort zone is based on occupant's thermal sensation in a climate controlled environment aka air conditioned spaces. The expanded comfort zone is based on increased air speeds provided by natural ventilation. The points correspond to the hourly conditions of the climate in relation to temperature (x-axis, measured in degrees Fahrenheit) and relative humidity (curved lines, shown as a percentage). High outdoor temperature and relative humidity that would be considered uncomfortable would be acceptable when natural ventilation is applied as increase air speed is used to offset these conditions.

⁴⁶ (Brager and de Dear 2001)

⁴⁷ (Brager and de Dear 1998)

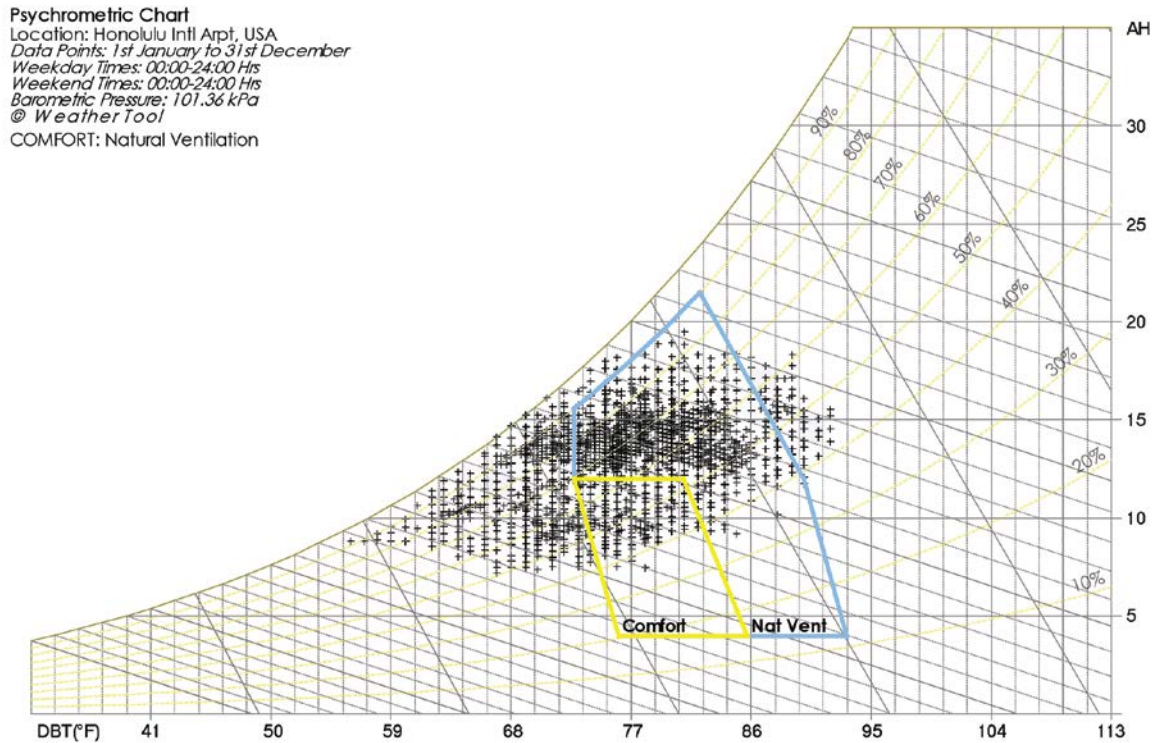

Figure 11. Psychrometric chart illustrating the potential for natural ventilation in Honolulu.

Source: Ecotect Weather Tool, Honolulu International Airport TMY3 weather data file

Despite these positive thermal comfort studies in naturally ventilated spaces, air conditioning is still widely used in the tropics as it can reduce both temperature and relative humidity – two main contributing factors that determines one’s perception of thermal comfort. A building in the tropics cannot rely purely on natural ventilation in providing thermal comfort. There are times during the year when thermal comfort is exceeded (e.g. points that fall outside the natural ventilation zone seen on the psychrometric chart, figure 11) thus requiring mechanical cooling to offset those conditions. This is otherwise known as mix-mode cooling and ventilation.

There is some contradiction to designing for mix-mode cooling and ventilation. Natural ventilation requires large openings in the building façade to maximize ventilation while air conditioning requires smaller openings or a sealed envelope to ensure regulated control of the internal environmental conditions. The fundamental challenge is designing a building envelope that works well with both natural and mechanical ventilation and cooling.

3.2 Acoustics

"Any sound that is unwanted is noise."⁴⁸ Openings in the building façade intended for passive cooling can bring in noise from the urban environment below. Hard horizontal and vertical surfaces commonly found in a city environment reflect sound rather than absorb them. Added with busy streets filled with motorized vehicles and mechanical equipment from surrounding buildings, noise levels are intensified in an urban setting as a result. Any means to reduce noise levels at the building envelope through filters also reduces air velocity therefore reducing the facades capacity to provide passive ventilation to the interior.⁴⁹ This is one of the main challenges when designing for natural ventilation in an urban setting. Many tall building designs incorporate sealed building envelopes as an easy solution to keeping noise from entering occupied spaces.

3.3 Indoor Air Quality (IAQ)

On average, people spend 90 percent of their times indoors.⁵⁰ Supplying adequate amount of fresh air to these indoor environments whether they are mechanically or naturally ventilated is critical to occupant's health and well-being. To provide acceptable indoor air quality (IAQ) an occupied spaced must bring in outside air at a rate that will not only replenish oxygen but expel carbon dioxide and odors produced by individuals and furniture within the building. Off gases from synthetic materials within the buildings also prone a threat to indoor air quality and should be expelled to prevent sick building syndrome (SBS). Poor maintenance of HVAC systems also has the potential to cause SBS. A study was done investigating occupant health of a fully air conditioned space. The results indicated that occupants reported having nasal congestion, pharyngeal symptoms, and lethargy.⁵¹ This study, as well as many others, has shown higher risks of sick building syndrome with occupants residing in air conditioned spaces compared to those residing in naturally ventilated spaces.

Openings in the building envelope do little with filtering the incoming air, especially the pollutants from vehicles and other mechanical equipment of buildings in

⁴⁸ (Grondzik, et al. 2010)

⁴⁹ Ibid

⁵⁰ (EPA 2009)

⁵¹ (Jaakkola and Miettinen 1995)

the surrounding area.⁵² Similarly to designing for acoustics, any attempt to filter the incoming air would reduce air velocity therefore reducing the effectiveness of natural ventilation for passive cooling. This is another challenge when designing for natural ventilation in an urban environment as the quality of the indoor air is determined by various factors associated with urban environments such as material selection, quality of outdoor air, climate, and airflow patterns around a buildings location.

There are IAQ standards stated in ASHRAE 62.1 that dictate the required quantity and acceptable quality of indoor air.⁵³ The required quantity of air can easily be determined once the designer knows the buildings usage, floor area, etc. One unpredictable factor, however, that designers face is the lack of well-established data of local and regional air quality. This plays a large role when designing for natural ventilation especially within an urban area. The standards provide a Ventilation Rate Procedure (VRP) to follow to determine whether quality of outdoor air is compliant with IAQ standards and acceptable for natural ventilation in buildings. The quality of outside air is first determined; if unsuitable the standards advise filtering the air before being used which inevitably leading to mechanical ventilation.

The Environmental Protection Agency (EPA) provides the National Ambient Air Quality Standards (NAAQS) to help gauge the level of air quality for specific cities within each state. Level of quality is rated Good, Moderate, Unhealthy (Sensitive Groups), Unhealthy, Very Unhealthy, or Hazardous. According to the NAAQS, Honolulu's ambient air quality has a rating of 29 (0-50 = Good) as of 2015 meaning it poses little or no risk.⁵⁴ Thus the use of natural ventilation in the city of Honolulu is fully capable in providing good indoor air quality without the need for filtration systems of any kind.

⁵² (Grondzik, et al. 2010)

⁵³ (ASHRAE 2013)

⁵⁴ (State 2015)



Figure 12. Honolulu's ambient air quality as measured by the NAAQS.

Source: State of Hawaii, Department of Health

3.4 Airflow, Spatial Geometry, and Ventilation

"Natural winds are turbulent winds, they are nearly always *unpredictable*."⁵⁵ Airflow can drastically alter due to other physical factors such as surrounding buildings despite general patterns found in wind charts and diagrams of a specific location. The complexities of wind flow around nearby buildings depend on overall building forms and façade design features that may act as wind breakers or wind scoops. There is a

⁵⁵ (Turner and Soar 2008)

predictable feature found in natural winds – the vertical wind speed gradient. Wind speeds increase with height.⁵⁶ Upper floors of a high rise require greater attention for mitigating higher wind speeds and pressures when designing for natural ventilation.⁵⁷ Special attention is also required for sizing and placement of façade openings at different floor levels as well as orientation to prevailing winds.

High rise designs are based on a simple model; that is a “concealed box (geometric form).”⁵⁸ According to Key Yeang, “architecture design of high-rise has remained unchanged since its invention of air conditioning. Its technology and engineering have become far better and much more sophisticated, but most of the high-rise buildings constructed today remain fundamentally similar in term of their built configuration.”⁵⁹ As a result, orientation, internal spatial geometry, and building envelope design have changed as consideration for passive cooling became less important with increasing reliance and convince of air conditioning.⁶⁰

What has become important for many high rise designs is efficiency in space planning by producing more rentable or sellable floor area onsite as preferred by developers. The double loaded corridor (DLC) spatial configuration is an economical solution to space planning as it optimizes unit count within a relatively small area. As a result, this configuration offers more unit count per floor relative to other configurations. However, despite economic values, this type of spatial configuration prevents cross ventilation for passive cooling as the central access corridor acts as an internal barrier to air flow. Large open and deep floor plans are another efficient method for space planning as they offer more leasable floor area. Such buildings, more prominent in office and commercial typologies, require large mechanical ventilation and cooling systems to provide thermal comfort due to it’s the inability to cross ventilate.

⁵⁶ (Yuan 1987)

⁵⁷ (Daniels 1997)

⁵⁸ (Ling, Ahmad and Ossen 2007)

⁵⁹ (Yeang 1996)

⁶⁰ (Grondzik, et al. 2010)

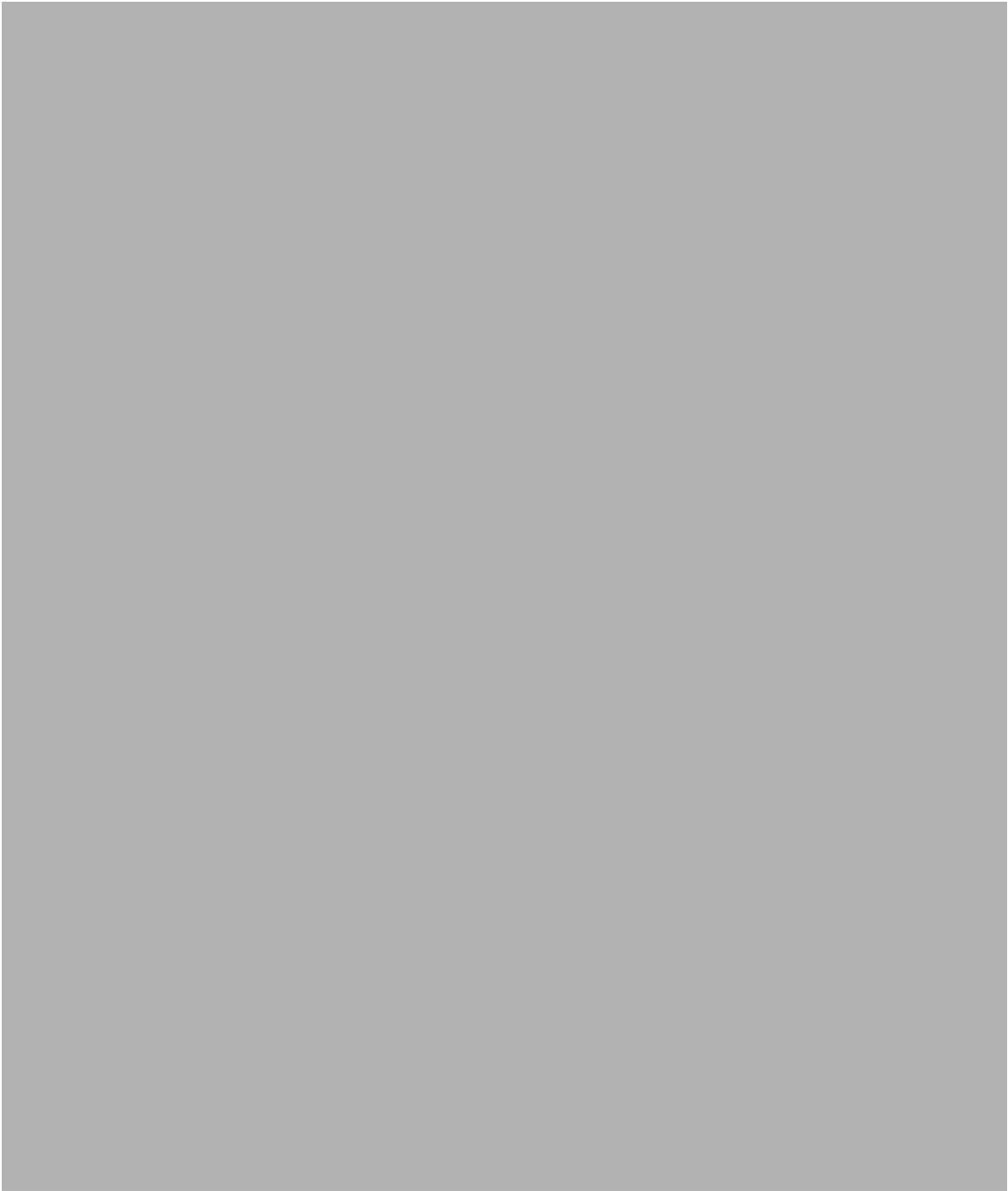

Figure 13. Space planning efficiency of the (a) double loaded corridor and (b) open floor plan. Both configurations optimize unit count and rentable floor area but lack the ability to provide effective thermal comfort through cross ventilation.

Source: *Mechanical and Electrical Equipment for Buildings*

A building must have the ability to capture and channel wind from one end to the other in order to be successful in cross ventilation.⁶¹ Cross ventilation depends on pressure differences between inlets and outlets, preferably located opposite from one another. ASHRAE's prescription for cross ventilation design is simple; the width of a space between two façade openings shall be no more than five times that of its ceiling height.⁶² Linear floor plan designs offer greater advantages for cross ventilation especially when longer portions of the building façade are oriented perpendicular to prevailing winds as can be seen in some pre-modern tropical vernacular models. Deep open floor plans, at most, exceed the prescribed design method for cross ventilation thereby surrendering to mechanical cooling and ventilation.

The DLC configurations are generally designed on an elongated floor plan but due to its major internal partition – the access corridor – it is inefficient in cross ventilation. Occupied units situated within a DLC configuration, for the exception of corner units, are only able to provide single-sided ventilation. A disadvantage in this type of ventilation is the lack of pressure differences along a single façade resulting in lack of air flow and speed to provide effective passive cooling.

Another disadvantage is its efficiency to provide effective natural ventilation in all units, both windward and leeward facing. A study done at the Lawrence Berkley National Laboratory shows that air flow rate of windward facing apartments units of a double loaded corridor high rise is greater than that of the leeward side.⁶³ In fact, windward facing units were over ventilated especially those located on high floors in direct correlation to the vertical wind speed gradient. Leeward facing apartments illustrated that air flow into the apartment was actually, in some cases, originating from the corridor – infiltration through door cracks – and then exhausted through leeward façade openings. The access corridor was the problem as it acted as a barrier to air flow thereby producing these results. The challenge is producing a configuration design that best supplies ventilation to each apartment regardless of being on the windward or leeward side of a building.

⁶¹ (Jatupatwarangkul 2012)

⁶² (ASHRAE 2013)

⁶³ (Feustel and Diamond 1998)

3.5 Building Codes

Naturally ventilated buildings must abide by several national and international standards mainly the American Society of Heating, Refrigerating, Air-Conditioning and Engineering (ASHRAE) due to its relation to indoor air quality and occupant thermal comfort. The International Energy Conservation Code (IECC) is also important in designing the building envelope as the selection of building materials and fenestration areas determines both the level of energy conservation and indoor thermal comfort.

Local standards include the Hawaii Energy Code that provides guidelines to building design in Hawaii. The state of Hawaii, Department of Business, Economic Development & Tourism (DBEDT) advise two simple design objectives when designing for energy efficiency homes in Hawaii – (1) “control heat buildup using orientation, landscape, and design strategies that keep heat away from and out of buildings” and (2) “use natural ventilation to remove heat and naturally cool interiors.”⁶⁴ These two design strategies are consistent with principles found in traditional tropical vernacular architecture as was discussed in the earlier chapter. These strategies and principles serve as a foundation for naturally ventilated building design in hot and humid climates. Yet it is rarely seen in many modern buildings in tropical conditions.

Any attempt to utilize pressure differences on the windward and leeward façades for induced cross ventilation would require a “porous” access corridor rather than one that acts as a barrier. However, fire code restrictions hinder the ability to do this. The double loaded corridor is required to have 1-hour fire proof rating as stated in the International Building Code (IBC).⁶⁵ This means circulation spaces like the access corridor needs to be nearly sealed making it difficult for cross ventilation.⁶⁶ Deep floor plans are also subject to single-sided ventilation because larger floor areas are too difficult to ventilate simply from the perimeter or building envelope. High rises with deep floor plans usually always incorporate mechanical ventilation and cooling to ensure adequate indoor air quality and thermal comfort especially for occupant’s location in the inner most area of the floor plate. This is seen more in office and commercial building typologies.

⁶⁴ (DBEDT 2001)

⁶⁵ (IBC 2009)

⁶⁶ (Gomaa 2013)

3.6 Viability of Natural Ventilation in Honolulu

Many of the design constraints discussed earlier offer challenges for designing naturally ventilated high rises in the tropics. High relative humidity is one of the biggest issues but studies show that natural ventilation cooling can provide the necessary thermal comfort by using increase air speeds to aid in the body's ability to lose heat. As the NAAQS suggests, outdoor air quality of the city of Honolulu is suitable making natural ventilation viable in urban Honolulu. Finally, there is the issue of utilizing cross ventilation in accordance with fire safety requirements associated with the double loaded corridor spatial configuration that need to be addressed. A spatial configuration that works well with cross ventilation and the double loaded corridor model is the fundamental challenge. A well-designed building envelope also affects a building's ability to cross ventilate and receive solar radiation therefore being a significant importance to occupant thermal comfort in naturally ventilated spaces.

CHAPTER 4

Repercussions of Economic Preferences Relative to Tall Buildings

This chapter expands on the economic factors discussed in the earlier chapter as well as the repercussions in building performance and occupant comfort that follows.

4.1 The Single and Double Loaded Corridor Spatial Configuration

Double loaded corridors (DLC) – also known as double loaded slab configuration, double loaded typology, or stacked “pancake” approach – are best known for its space planning efficiency.⁶⁷ This spatial typology includes a linear circulation space – an access corridor – with units on each side separated by walls that run floor to ceiling. From an economical perspective, the DLC spatial configuration is preferred because of its ability to maximize unit count in a small area. This spatial configuration prevents cross ventilation for passive cooling mainly because the access corridor acts as an internal barrier to air flow. With increasing reliance and convenience of mechanical ventilation and cooling along with its space planning efficiency, this slab configuration has become a popular model for many high rise designs.

“Cross ventilation in a room is only guaranteed when the room has two (preferably) opposite windows with high pressure difference across them.”⁶⁸ Therefore, apartment units of a double loaded corridor design are generally limited to single-sided ventilation which is moderately effective compared to the potential cooling benefits of cross ventilation in hot and humid climates.⁶⁹ Corner units do have an exception as they provide the opportunity for two sides of wall openings but they only contribute to a small percentage of the total occupied units of a tall building. As a result, center located units of DLC typologies surrender to the more energy intensive approach to provide thermal comfort through the utilization of mechanical cooling and ventilation.

⁶⁷ (Rutes, Penner and Adams 2001)

⁶⁸ (Gomaa 2013)

⁶⁹ Ibid

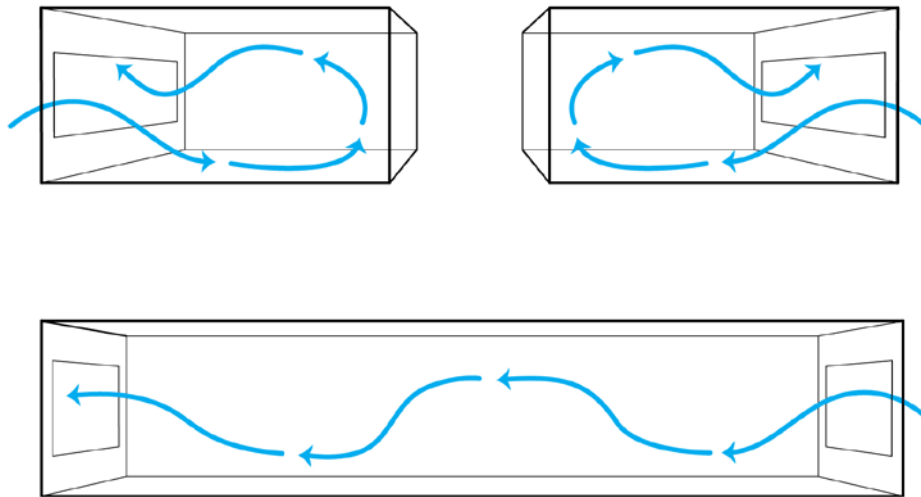

Figure 14. Air flow relative to the section perspective of a (top) double loaded corridor and (bottom) single loaded corridor spatial configurations.

Source: Drawn by author

The single loaded corridor can offer double-sided ventilation while being as efficient in space planning as the DLC configuration. Yet, this configuration is not very popular. One of the main issues in regards to the single loaded corridor (SLC) spatial typology is privacy. The access corridor is generally placed on one (external) side of the building. To utilize cross ventilation occupants must open their doors or windows to the access corridor. As a result, private spaces are opened to the public circulation space which is not generally an ideal situation despite advantages in utilizing cross ventilation in providing passive cooling.

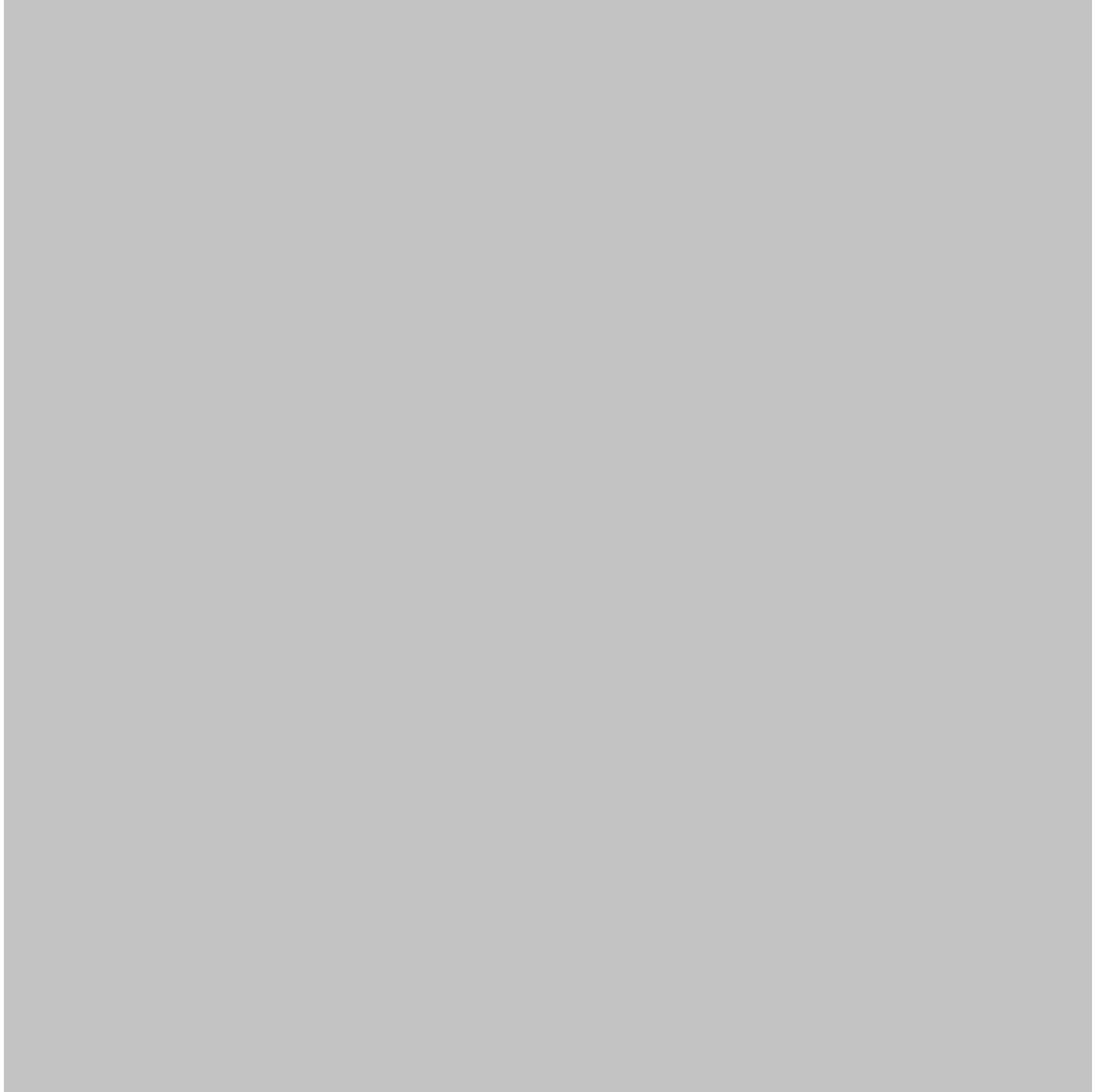

Figure 15. Traditional double and single loaded corridor spatial configuration relative to access corridor locations.

Source: *The Good Solutions Guide for Apartments*, Auckland City Council

The DLC spatial typology also affects external air flow patterns as the wind is forced around the building rather than through it.⁷⁰ This is more prominent in high rises with sealed building envelopes. Altered air flow pattern around the building can drastically affect other nearby buildings as well as pedestrians at ground level as it may cause unwanted gusts of wind. It is clear that although the double loaded corridor

⁷⁰ (Grondzik, et al. 2010)

design may provide an economic solution to spatial configurations for tall buildings it hinders in overall natural ventilation performance.



Figure 16. Wind patterns around various building forms with sealed building envelopes.

Source: *Wind Engineering*, Cermak

4.2 The Glass Curtain Wall Building Envelope

Glass curtain wall systems are highly popular for tall building designs, some say it is a very “contagious disease way-too-much-glassia.”⁷¹ There are several reasons for this, one being the economic value. From a developers standpoint these systems are “a lot cheaper and a lot easier to work with one trade, the window wall supplier, than to coordinate among trades when mixing precast concrete or brick with glass.”⁷² From an occupant standpoint a “space with a generous floor-to-ceiling height appears less constrained and is ‘easier to breath in’” thereby being more favorable.⁷³ Along with appearing less constrained, the view plane is also critical to the sales/rental pricing of any high rise apartment unit as it provides a visual connection to the outdoors.⁷⁴ Many operable windows come with mullions which can obstruct views thus leading many units

⁷¹ (Alter 2011)

⁷² Ibid

⁷³ (Kleiven 2003)

⁷⁴ Ibid

to incorporate fixed picture windows (that would otherwise have fewer mullions and provide greater views as a result). Due to reliance of large HVAC systems in providing thermal comfort, designers will often choose to create a “sleek impression” overlooking the high energy usage and emissions of greenhouse gases that follows.

Despite their economic value and convenience, others see these wall systems as an “energy-consuming nightmare” because a lot of energy is required for heating and cooling at the perimeter of the building to provide thermal comfort.⁷⁵ John Straube, an associate professor at the Waterloo and principle at Building Science Consulting Inc., argues that despite high performance glazing they have “little ability to control heat flow and solar radiation” with R values equivalent to ½” fiberglass.⁷⁶ There are high quality assemblies out there that are R-12 but can be very costly especially if the building envelope is designed to be mostly glass. Straube believes “a simple low-cost wall with only an inch of continuous rigid insulation will provide significantly better control of heat flow” than most of the curtain wall systems used in tall buildings today.

4.3 The Viability of the Skip-Stop DLC and Balcony Design

Skip-stop double loaded corridor (SSDLC) refers to “a building that has a double loaded (access) corridor on every second level so that every other level has a dual aspect apartment.”⁷⁷ The term “skip-stop” refers to a lift (elevator) skipping every other floor.⁷⁸ Similarly to the traditional economically preferred DLC, the spatial configuration of skip-stop DLC utilizes a central access corridor with units arrayed on each side, a method used for efficient space planning. However, the major difference between the two is that units have double-sided fenestration providing more efficient passive cooling through cross ventilation than single-sided ventilation of a DLC configuration.

⁷⁵ (Straube 2011)

⁷⁶ (Alter 2011)

⁷⁷ (Auckland 2007)

⁷⁸ Ibid

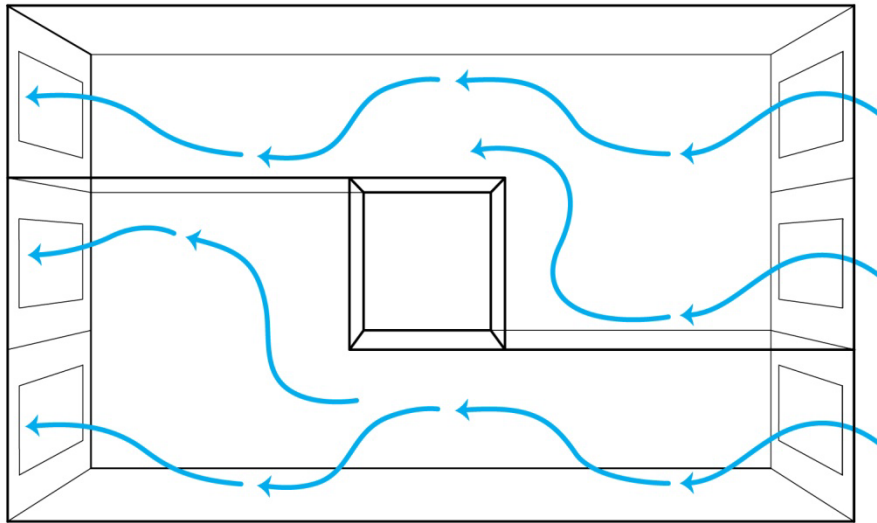

Figure 17. Air flow relative to the section perspective of a skip-stop double loaded corridor spatial configuration.

Resource: Drawn by author

The spatial geometry of a skip-stop DLC configuration, having double-sided ventilation, is an adequate solution to cross ventilation and the double loaded corridor dilemma. In regards to space planning it may not have the same efficiency in maximizing unit count as the DLC configuration but provides greater usable floor area relative to circulation area. Space that would otherwise be an access corridor is regained as useable floor area due to the configuration of each unit. As a result, the skip-stop spatial configuration has the potential to lower the need for mechanical cooling and ventilation therefore lowering building energy consumption while remaining an economic value to developers for its space planning efficiency at the same time.

The skip-stop double loaded corridor spatial configuration can be arranged with other various types of apartment unit configurations. This offers more choices for potential buyers as the building is able to “adapt more easily to the changing social needs of the occupants” compared to the stacked pancake approach.⁷⁹ Double height ceilings associated with these duplex units can also provide greater day lighting as well as dual aspects (views) in comparison to single aspect apartment units found in the traditional double loaded corridor configuration. These qualities are not commonly

⁷⁹ (Auckland 2007)

found in many high rise residential buildings and can be of great value to a wide variety of user groups and developers due to its unique design.



Figure 18. Skip-stop spatial configuration with other various types of apartment units in a single building accommodating a wide variety of user groups.

Source: *The Good Solutions Guide for Apartment*, Auckland City Council

Balconies not only act as box shading devices but further enhance the occupant's connection to the outdoors. It can also be used as a means to mitigate high wind speeds associated with high rise apartment units.⁸⁰ "Balconies that are fully recessed within the overall building form are to be preferred over those that project fully beyond the face of the building."⁸¹ This offers better weather protection as the balcony space acts as a buffer between the external and internal environmental conditions. With

⁸⁰ (Auckland 2007)

⁸¹ Ibid

shading provided by balconies, the fenestration area could also increase thereby increasing day lighting as well as ventilation openings to improve thermal comfort.



Figure 19. Day lighting effects of various apartment unit designs. The skip-stop configuration can best relate to the diagram on the bottom left (double height glazing). Utilizing recessed balconies provide the necessary shading in minimizing solar heat gain as demonstrated in the upper right.

Source: *The Good Solutions Guide for Apartment*, Auckland City Council

The potential benefits of the skip-stop double loaded corridor spatial configuration along with a box shading device or balcony for shading and increased fenestration area illustrate its viability to become part of a new tropical high rise model. This spatial typology and building envelope design resemble much of pre-modern tropical vernacular models which minimize solar heat gain and maximize ventilation at the same time. The objective of this project was to test the viability of a skip-stop double loaded corridor spatial configuration with a well-designed building envelope as to potentially improve thermal comfort without the use of air conditioning in a hot and humid climate.

CHAPTER 5

Unité d'Habitation by Le Corbusier

The previous chapter illustrated the potential benefits of a skip-stop double loaded corridor spatial configuration in providing efficient cross ventilation and space planning for vertical development. This slab configuration is not entirely new to the architecture world as it was utilized in a few projects more than half a century ago. Le Corbusier designed a series of housing projects throughout Europe from the early-50's to mid-60's that utilized the skip-stop configuration; called Unité d'Habitation meaning *housing unit*. The first and most notable project of this series of buildings is located in Marseilles, France. This chapter discusses the orientation, spatial geometry, and building envelope design of the Unité d'Habitation that provided a foundation for the development of the simulation model to be tested relative to the single and double loaded corridor models.

5.1 Marseilles Climate

Marseilles climate is classified as Mediterranean with conditions that range from cool-cold humid, moderate, to warm dry throughout the year. This is more clearly illustrated on the Psychrometric chart, figure 20. Average high temperatures range from 82-86°F during the summer and 53-55°F during the winter. Fluctuations between day and night can be up to a 20°F difference despite seasonal changes.

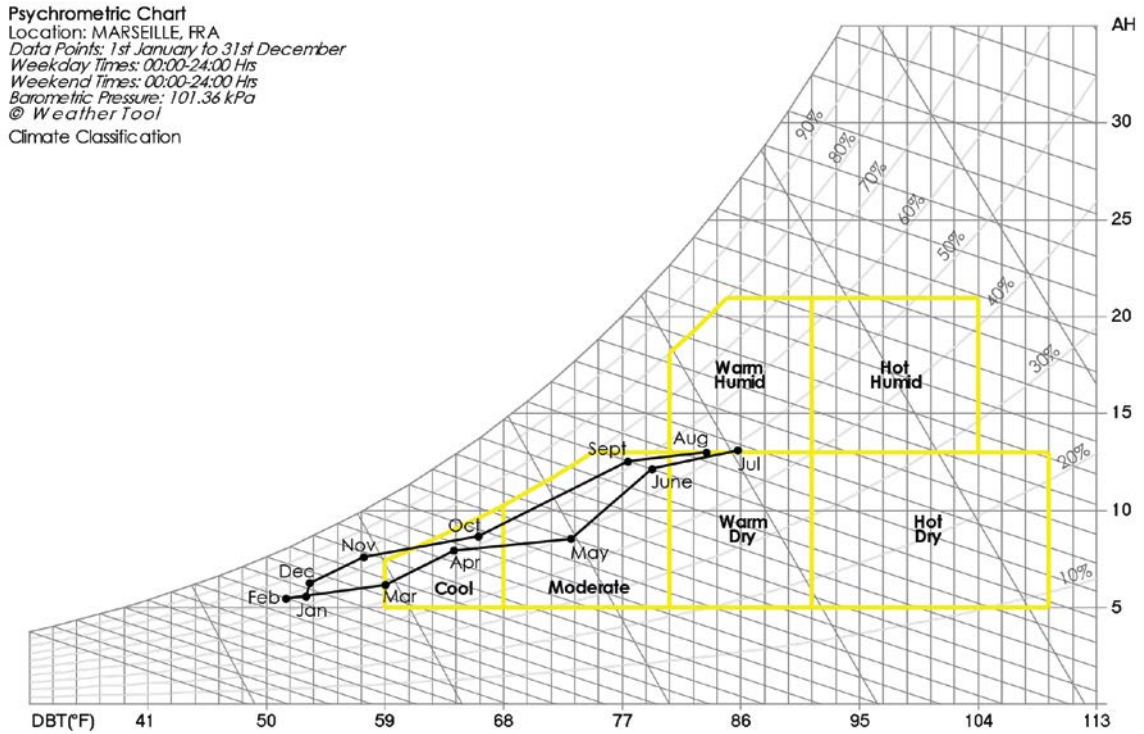

Figure 20. Marseille, France psychrometric charts graphs the thermodynamic parameters of air in its location taking into account dry-bulb temperature, wet-bulb temperature, dew point, relative humidity, humidity ratio, and enthalpy. This figure charts out the monthly average conditions of these parameters relative the climate classifications.

Source: Ecotect Weather Tool, Marseille TMY3 weather data file

The city experiences omnidirectional wind patterns with cold dry wind called Mistral originating from north-west and west during winter and less-frequent hot sand-bearing wind called Sirocco from the south-east and east direction. These two opposing wind patterns present themselves as a problem for traditional double loaded corridor designs as one side of the building will experience a higher ventilation rate than the other during difference times of the year. However, the design of the Unité d'Habitation provided a solution to this dilemma with the use of the skip-stop double loaded corridor spatial configuration allowing wind to enter each unit from either side of the building.

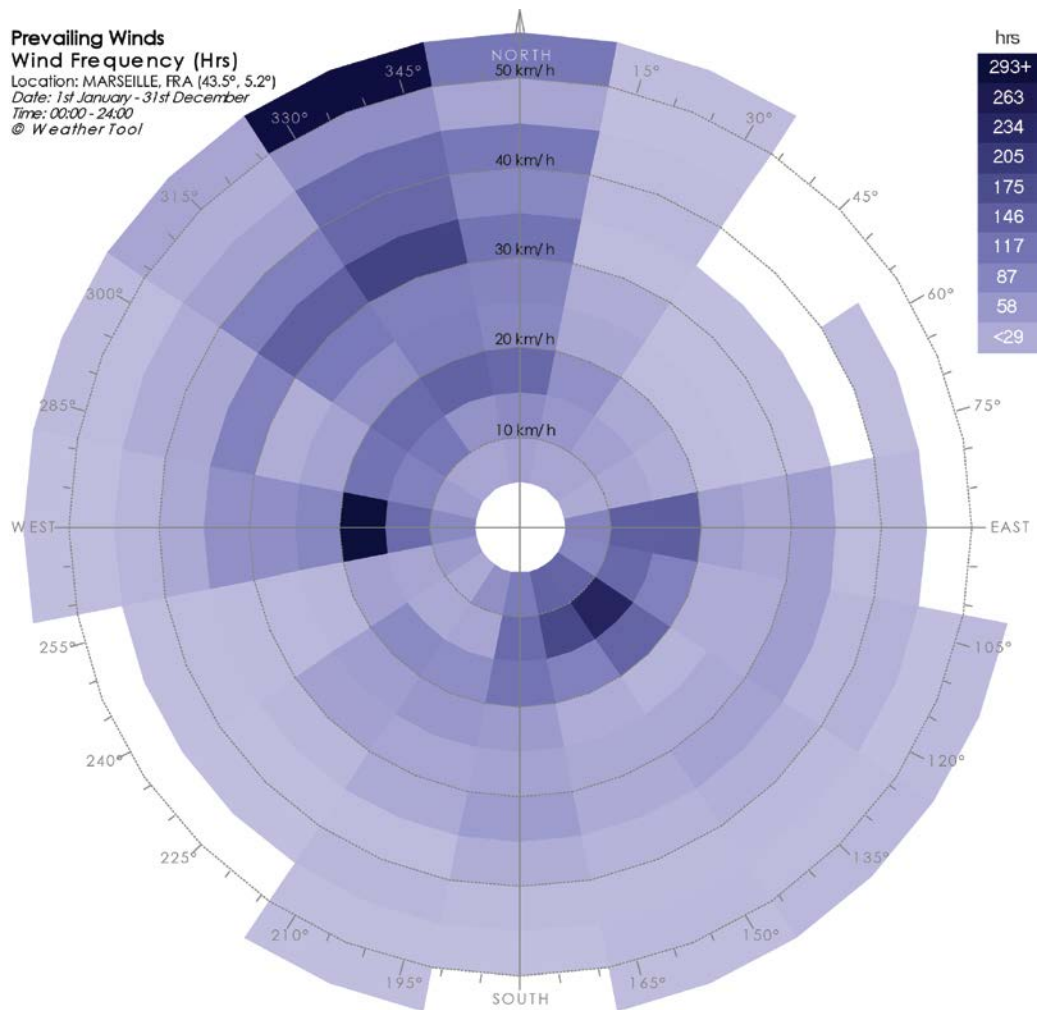

Figure 21. Wind rose illustrates the local wind seeds, direction, and frequency throughout the year.

Source: Ecotect weather tool, Marseilles TMY3 weather data file

Although this building was designed with natural ventilation in mind, according to the psychrometric chart, figure 22, a large portion of the year falls out of the designated comfort zone described by ASHRAE standards. Thermal discomfort is generally the result of being too cold rather than too hot. Testing this spatial configuration for natural ventilation in a tropical hot and humid climate such as Hawaii could have the potential to provide adequate thermal comfort compared to the colder climate of which it is currently located in.

Psychrometric Chart
 Location: MARSEILLE, FRA
 Data Points: 1st January to 31st December
 Weekday Times: 00:00-24:00 Hrs
 Weekend Times: 00:00-24:00 Hrs
 Barometric Pressure: 101.36 kPa
 © Weather Tool
 Comfort with Natural Ventilation

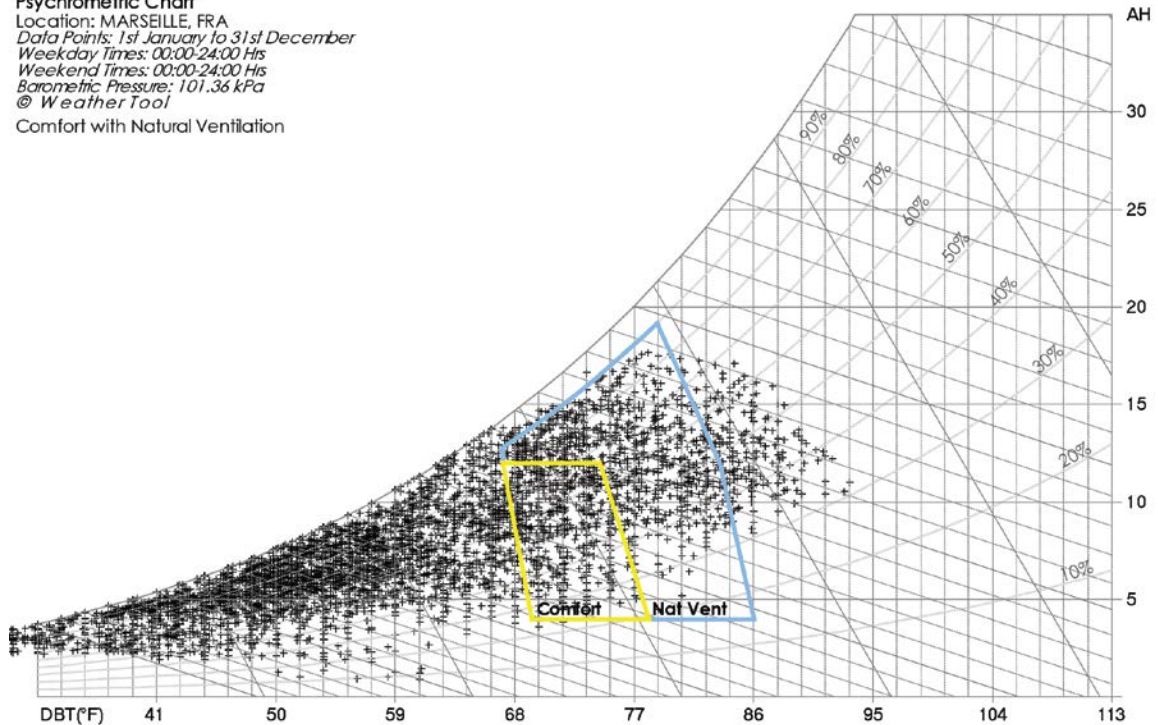

Figure 22. The points graphed on this psychrometric chart represent hourly conditions of Marseilles, France relative to the standard thermal comfort threshold and expanded thermal comfort threshold with the introduction of natural ventilation.

Source: Ecotect Weather Tool, Marseille TMY3 weather data file

5.2 Orientation

Unité d'Habitation can be described as a linear concrete block oriented to reflect the sun's path (longer faces oriented east and west, shorter faces oriented north and south). Similar to other works of Le Corbusier, one of the main driving forces in the design of this building was to reflect elements found in the natural world, one of them being the path of the sun in the sky as it rises in the East and sets in the West. Although solar shading is provided via balconies, the orientation was intended to allow for passive heating in the early morning and late afternoon as Marseilles climate is relatively cool-cold most of the year, as illustrated in the psychrometric chart, figure 22.⁸²

⁸² (Essays 2013)

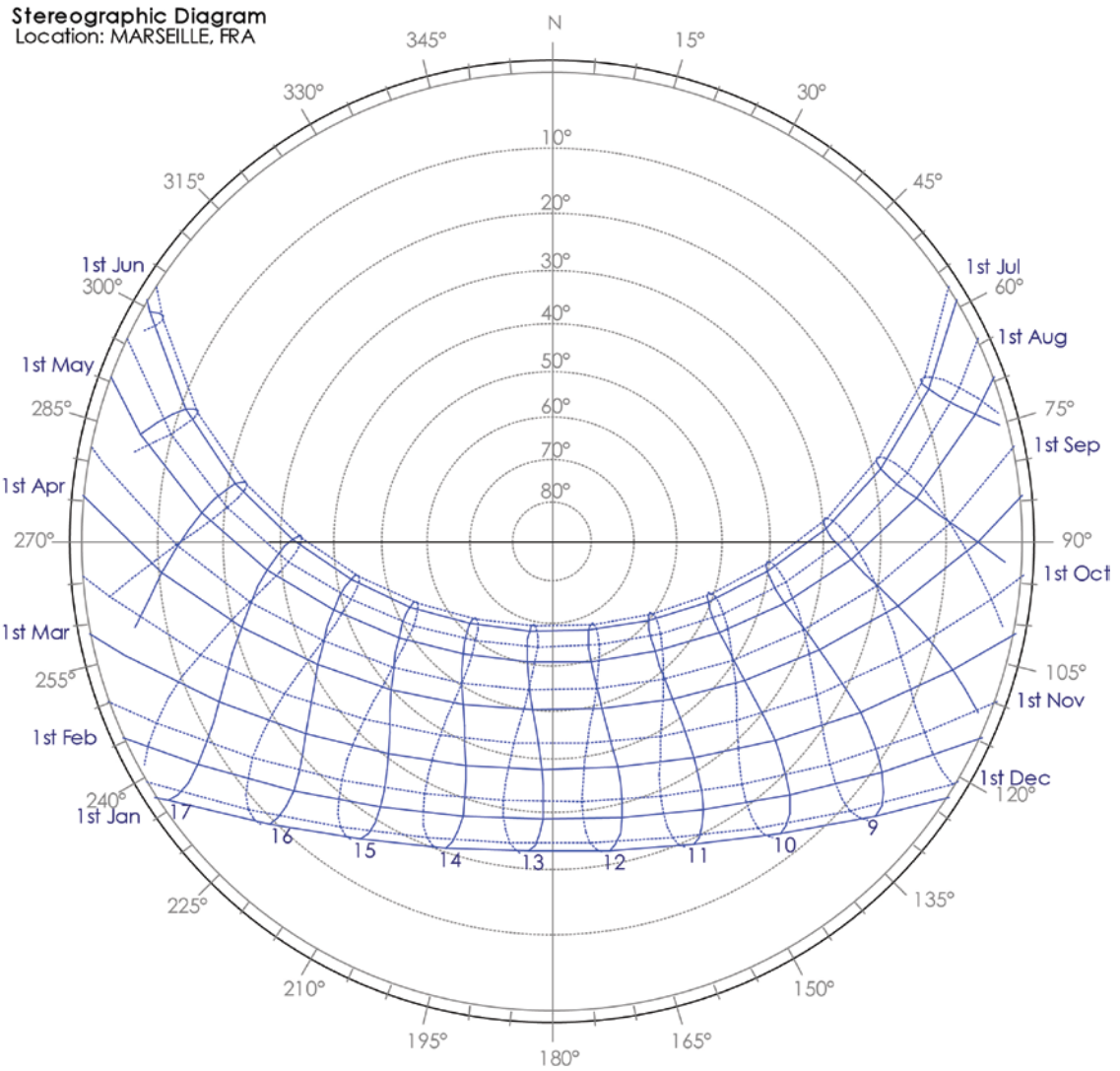

Figure 23. Marseilles, France: sun path diagram illustrating the position of the sun in the sky throughout the day and year.

Source: Ecotect Weather Tool, Marseilles TMY3 weather data file

On the contrary, building orientation in the tropics, along with its configuration and geometry, relative to the sun attempts to minimize rather than maximize heat gain. Narrower building facades oriented east/west is best for reducing exposure from low sun angles during early mornings and later afternoons. While elongated south facades are expose to higher solar radiation during the winter months this orientation provides effective shading opportunities such as large horizontal shading devices. This prompts

the fundamental research question; will a skip-stop configuration work well in a different orientation that is better suited for tropical hot and humid conditions?

The orientation of the building also takes advantage of the local omnidirectional wind patterns to provide natural ventilation to each apartment unit. Prevailing winds may originate from various directions throughout the year as shown in the wind rose (Figure 20) but with the double opposing façade openings provided by the spatial geometry allows for a higher potential of harnessing the wind for cross ventilation purposes. This was not intentionally the main design driver but rather to maximize heat gain with building orientation relative to the sun exposure.

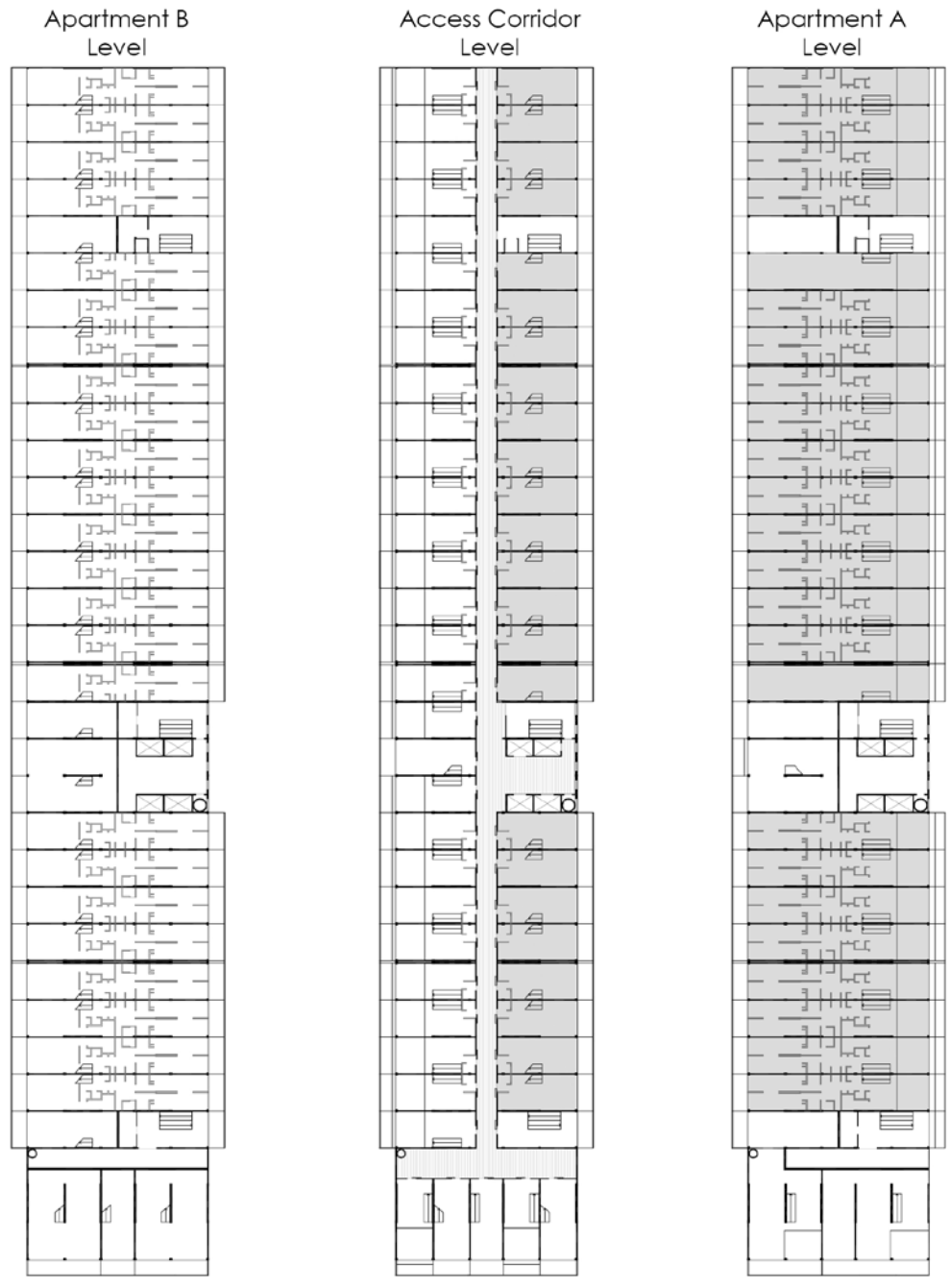



Unité d'Habitation Building Floor Plan

Figure 24. Typical Unité d'Habitation building floor plan, individual apartments oriented east and west for passive heating.

Source: Arch Daily Classics, redrawn by author

5.3 Spatial Geometry and Configuration

The Unité d'Habitation of Marseilles is 450'-0" long, 80'-0" wide, and 185'-0" tall. The 18-storey building includes 337 individual apartment units, shops, educational facilities, and a rooftop terrace that provides even more amenities. Le Corbusier described the skip-stop spatial configuration "like wine bottles on a rack" where two-story apartment units interlocked around a central access corridor which he called *streets*.⁸³ The interlocking spatial geometry of the apartment units in relation to one another, the building only required an access corridor on every third floor.⁸⁴ This is clearly seen in Figure 25. As a result, the 18-storey building had just five main access corridors that led to the apartment units. The utilization of the interlocking skip-stop configuration allowed the building to offer 23 different types of apartment units that could accommodate various user groups from one person to a generous family size.⁸⁵ As mentioned in the previous chapter, the use of the skip-stop configuration has the potential to be an economic value to an array of home owners and developers.

⁸³ (Glancy 2013)

⁸⁴ (Fearson 2014)

⁸⁵ Ibid

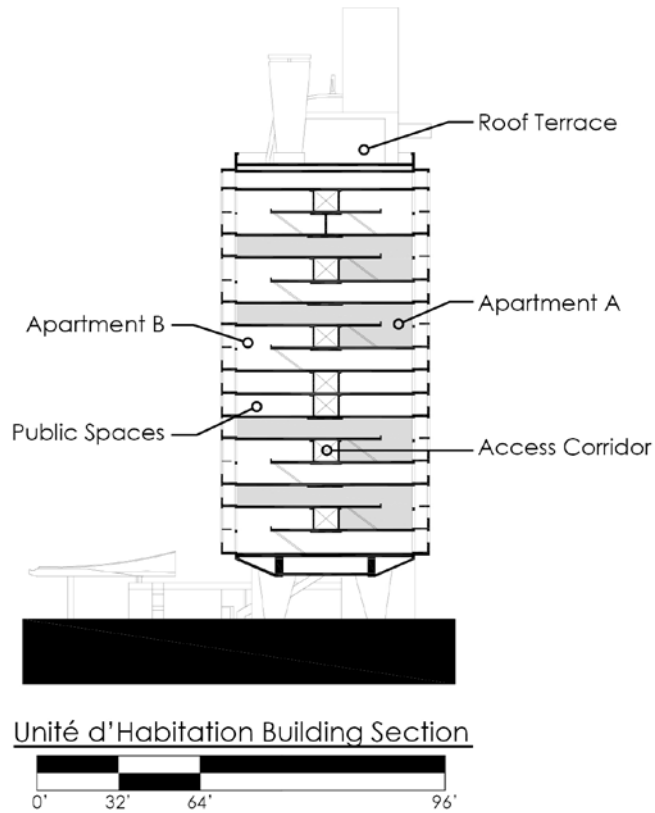

Figure 25. Unité d'Habitation staggered spatial arrangement of A and B type apartments.
Source: Arch Daily Classics, redrawn by author

There are two common types of units (A and B) found in the building that have roughly 1,000 square feet with three bedrooms, two bathrooms, double height living space, and a kitchen/dining area (illustrated in Figure 26 and 27). Both units had a mezzanine that was either a kitchen space or a bedroom, depending on the apartment geometry. The spatial geometry of each unit allowed for double-sided ventilation and day lighting with recessed windows and balconies.



Figure 26. Sections of two common apartment units in the Unité d’Habitation building inspired by wine bottle racks.

Source: Arch Daily Classics, redrawn by author

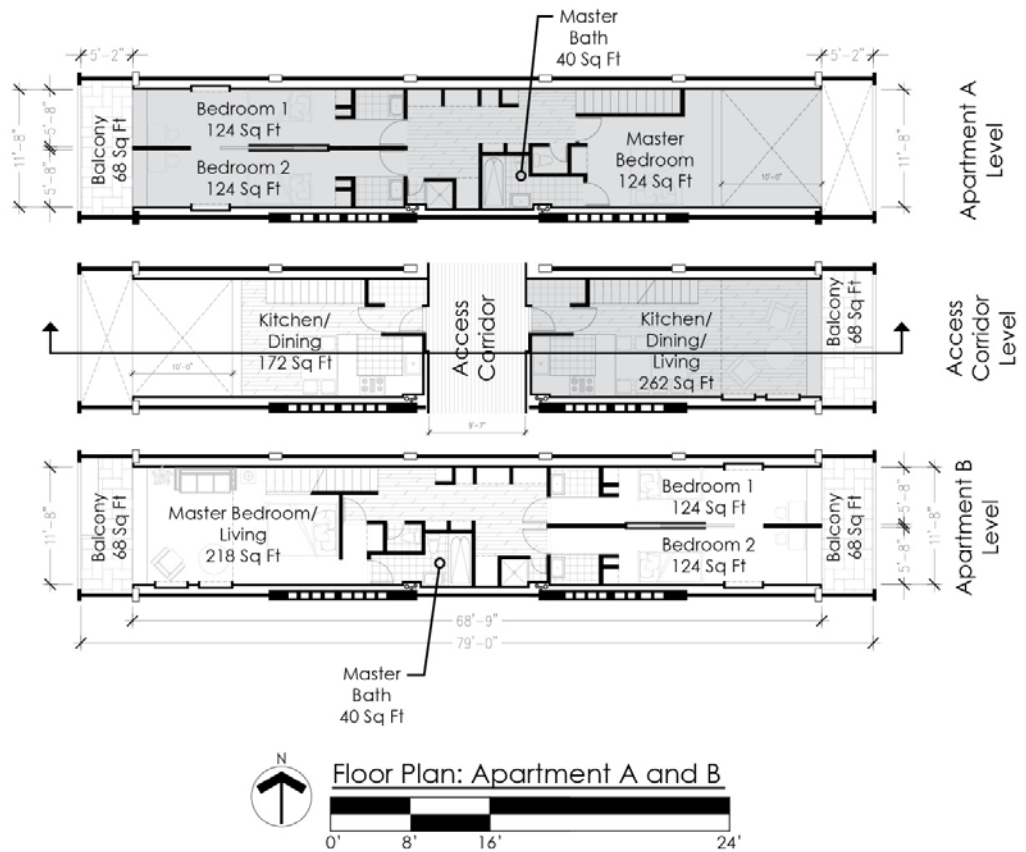

Figure 27. Floor plan of two common apartment units in Unité d’Habitation.

Source: Arch Daily Classics, redrawn by author

5.4 Building Envelope

As many other buildings built during the post-war era, Unité d'Habitation of Marseilles was built with "bare" concrete associated with brutalism-style architecture due to the limited supply of steel at the time of its construction. Interestingly, Le Corbusier enjoyed the idea of using "bare" concrete as it shows age and character over the years as a direct reflection of the human skin.⁸⁶ Each apartment unit is equipped with two balconies, one on each side. Recessed windows mainly consisted of accordion-type operable doors with a 1'-6" high thresholds that acted as secondary seating. Fixed windows were located above the double height living spaces in each unit.

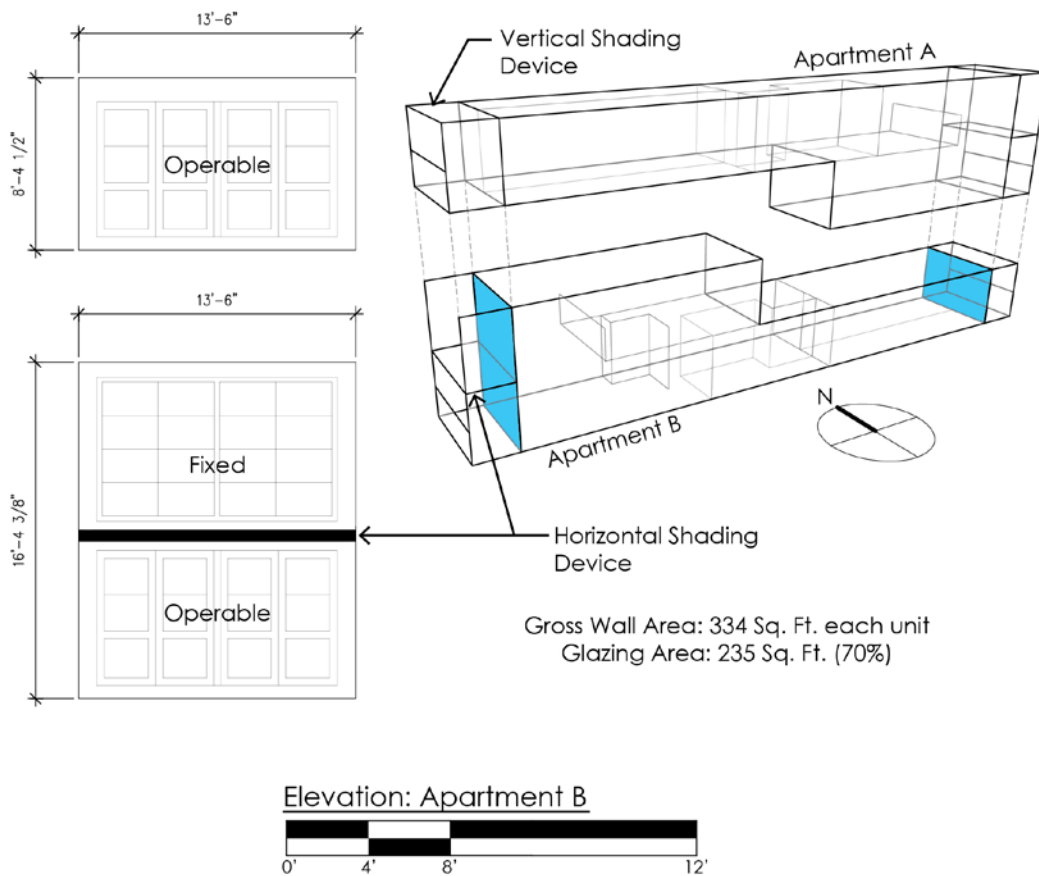

Figure 28. Unité d'Habitation building envelope design.

Source: Drawn by author

⁸⁶ (Essays 2013)

The building envelope design incorporated balconies providing adequate shading for both the low and double height ceiling spaces. Balcony railings were also porous as to not act as a barrier to air flow. Thresholds were raised to provide seating areas in the transition between indoor and outdoor spaces. The resulting building envelope design extended the indoor living areas to the outdoors by utilizing the balcony as a buffer.

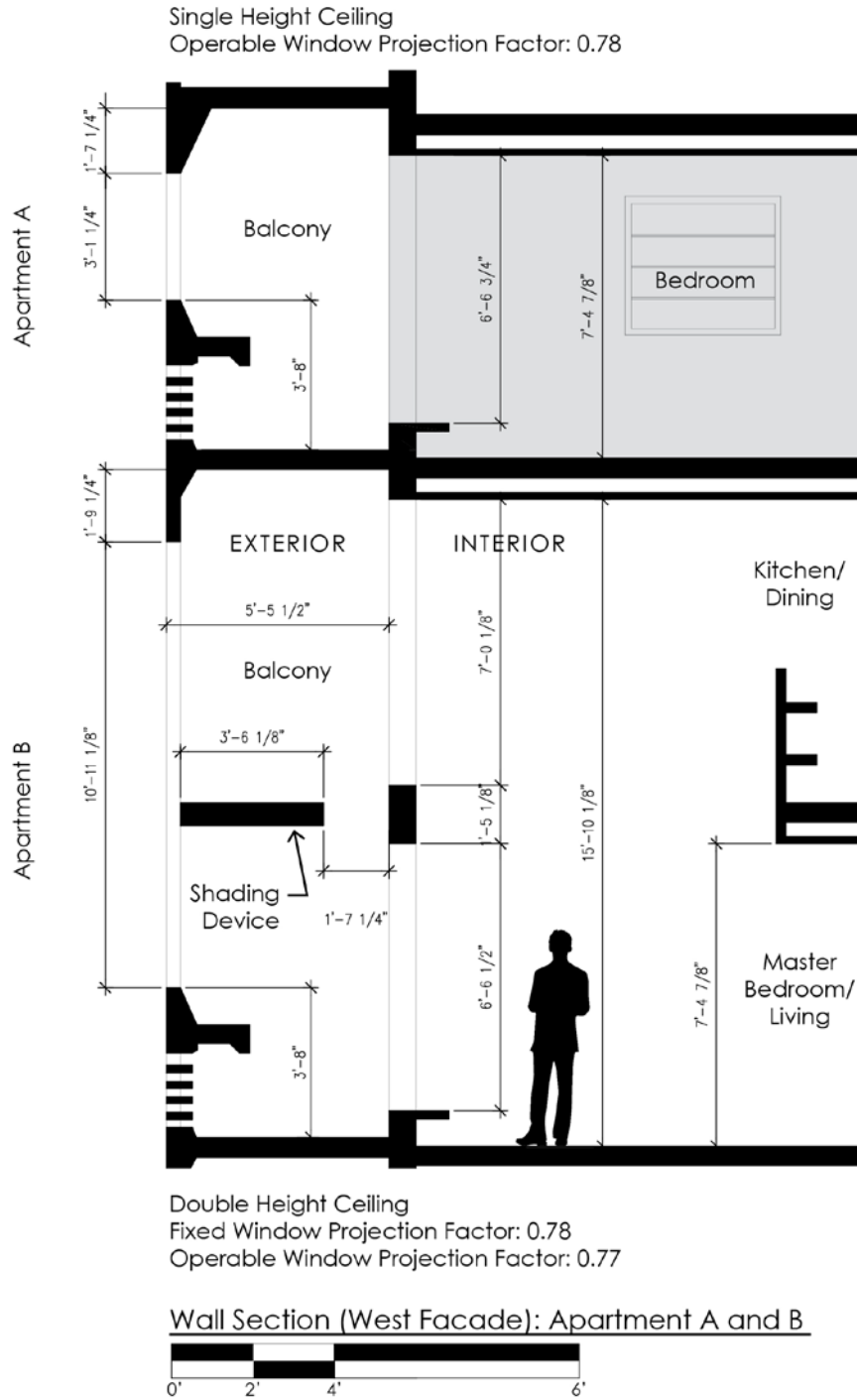

Figure 29. Unité d'Habitation building envelope design – shading devices and balcony details.

Source: Arch Daily Classics, redrawn by author

PART II
RESEARCH PROJECT

CHAPTER 6

Research Objective

According to the State of the Tropics 2014 Report the tropics will be home to most of the world's population and two-thirds of its children by the year 2050.⁸⁷ As a result, greater pressure is being put on the natural environment as the issue of land scarcity becomes more prominent especially for those residing in the oceanic regions of the world. Hawaii, specifically Honolulu, has already begun taking the concept of vertical cities into mind as a recent report indicates a population growth of 1% (about 14,000 residents) annually state-wide with increase in jobs to follow.⁸⁸ High rises are increasing in demand as they provide high-density housing and businesses in a vertical manner all within a smaller land area. However, such building typologies are known for their high energy consumption and greenhouse emissions as a result of using large Heating, Ventilation, and Air-Conditioning (HVAC) systems in providing thermal comfort.

Double loaded corridor (DLC) spatial configurations, where apartments or individual units are placed on both sides of an access corridor, are economically advantageous for high-density residential building typologies because it optimizes unit count in a relatively small area. Despite its economic advantageous this spatial configuration fails in providing cross ventilation for passive cooling. This is because the access corridor itself acts as an internal barrier to cross ventilation resorting to the less effective single-sided ventilation or mechanical cooling for thermal comfort. The fundamental challenge was finding a solution that works well with cross ventilation and the DLC configuration to improve thermal comfort through passive methods and reduce the need for air conditioning.

The skip-stop double loaded corridor (SSDLC) spatial configuration found in Le Corbusier's Unité d'Habitation could be a potential solution in providing efficient cross ventilation for double loaded corridor configurations. The configuration allows for two-level units to be placed alongside a central access corridor while simultaneously providing double-sided ventilation. A building with this configuration only requires a corridor and lift (elevator) at every other floor hence the term "skip-stop."⁸⁹ This

⁸⁷ (Tropics 2014)

⁸⁸ (Shimaogawa 2014)

⁸⁹ Ibid

configuration has the ability to not only provide efficient cross ventilation but space planning for vertical development with fewer access corridors and increase usable floor area per unit. This solution could potentially become a new model for future naturally ventilated high-density building typologies in hot and humid climates.

The objective of this project was to investigate the potential to improve thermal comfort without mechanical cooling in a Unité d’Habitation inspired SSDLC configuration in comparison to a traditionally economically preferred DLC as well as a single loaded corridor (SLC) configuration. The effects of building envelope design on thermal comfort such as shading projection factors and window opening areas were tested for each configuration. Behavioral changes on thermal comfort such as increased local air speeds via ceiling fans were also tested to improve thermal comfort conditions in each configuration. The results will be beneficial to architects practicing in Honolulu and other tropical cities around the world as it not only solves the issues mentioned above but provide occupants with well-designed adaptive environments that work efficiently with passive ventilation and cooling. In addition to this, the results illustrate the potential to reduce the need for air conditioning in providing thermal comfort thus reducing building energy consumption and greenhouse gas emissions for future high-density building typologies.



Figure 30. Le Corbusier’s Unité d’Habitation skip-stop double loaded corridor spatial configuration inspired by a “wine bottle rack”.

Source: Arch Daily Classics, redrawn by author

6.1 Analysis Plan

There does not seem to be an existing body of knowledge that tests the thermal comfort conditions of a skip-stop double loaded corridor configuration. Without field validation of existing precedents like Unité d'Habitation, the absolute magnitude of variables is nearly impossible to measure. Therefore, this project utilized simulations to obtain good estimates on the thermal comfort outcome of three spatial configurations – double loaded corridor (DLC), single loaded corridor (SLC), and skip-stop double loaded corridor (SSDLC). The estimated thermal comfort results were not seen as absolute (predicted) but relative (comparative) to the various conditions being tested.

Tropical vernacular designs differ from region to region based on geography, local wind pattern, material sources, etc., all sharing but two basic principles – maximize natural ventilation and minimize solar heat gain. The three configurations or models were put to the test using these two primitive design principles as a basis for a series of parametric analyses. These analyses investigate the effects of orientation, spatial geometry/configuration, shading projection factors, and window opening areas on thermal comfort in naturally ventilated spaces. These factors greatly affect a buildings ability to passively ventilate and receive solar radiation. Modifications to local air speeds via ceiling fan were also done to further improve thermal comfort. The intent of this project was to demonstrate the importance of spatial configuration, building envelope design, and behavior changes on thermal comfort and natural ventilation in a hot and humid climate.

CHAPTER 7

Research Methodology

This project utilized simulations to obtain good estimates on the thermal comfort outcome of three spatial configurations – double loaded corridor (DLC), single loaded corridor (SLC), and skip-stop double loaded corridor (SSDLC). This chapter discusses the metric used to measure thermal comfort, type of modeling, simulation tools, location of analysis, and breakdown of each tested model.

7.1 Measuring Thermal Comfort

Thermal comfort depends on far more than just air temperature. It is determined by three categories of factors – individual, environmental, and psychological.⁹⁰ Six (6) main factors that influence thermal comfort are those that determine heat gain and loss. These individual and environmental factors, illustrated in figure 31, are quantifiable and therefore used in the analysis to determine thermal comfort within each configuration model. Psychological factors on thermal comfort such as color, texture, sound, light, movement, aroma, and individual expectations as defined by the American Society of Heating, Refrigerating, and Air-Conditioning Engineers (ASHRAE) are difficult to quantify and therefore were not factored into the analysis.

Environmental factors – air temperature (°F), radiant temperature (°F), air velocity (ft/s), and relative humidity (%) – are dependent on one's environment and can vary from location to location. These conditions were obtained in the form of a weather data file specific to the location this analysis was based in. Although air velocity is considered an environmental factor that can only be obtained via weather data file it does not mean it cannot be controlled or manipulated. Besides sculpting a space to receive, reject, or channel wind for effective natural ventilation, other methods of controlling or manipulating air flow for improved thermal comfort are window openings and ceiling fans. A parametric analysis was done to test the effects of various window opening areas and increased local air speeds via ceiling fans on thermal comfort.

Individual factors – metabolic rate (MET) and clothing insulation (CLO) – are determined on an individual basis. Metabolic rate is the rate at which we as human

⁹⁰ (Grondzik, et al. 2010)

beings generate heat based on our level of activity, where one MET is defined as $50\text{k(calories)/h m}^2$ (18.4 BTU/h ft^2).⁹¹ Increase in activity increases metabolic rate (heat generation). Simulations were conducted on a residential building typology where occupants were assumed to be seated at rest (MET = 58.2).

Our skin is important in regulating heat flow where interactions such as touch (conduction) and air (convection and radiation) can affect the body's surface temperature and thus comfort. Clothing acts as our second skin which is measured in CLO units. "One CLO is equivalent to a typical American man's business suit in 1941 when the concept of CLO was developed."⁹² A decrease in surface and air temperature, as experienced in cold climates, would require increase insulation – more clothing – as to regulate the body's core temperature. Passive heating such as exposure to solar radiation could also provide comfort for occupants in cold climates.

In contrast, in warmer climates the skin requires more exposure to moving air for heat lost.⁹³ The skin also requires protection from solar radiation as it would increase the body's temperature and result in thermal discomfort. Simulations were conducted with the assumption that the occupants of the residential building typology were wearing typical clothing such as trousers and a short-sleeve shirt (CLO = 0.5). Both clothing and metabolic rate were fixed throughout the analysis.

⁹¹ (Grondzik, et al. 2010)

⁹² Ibid

⁹³ Ibid



Air Temperature (°F)

The air temperature is the average temperature of the air surrounding the occupant, with respect to location and time.



Mean Radiant Temp (°F)

The radiant temperature is related to the amount of radiant heat transferred from a surface, and it depends on the material's ability to absorb or emit heat, or its emissivity. MRT cannot be measured, only calculated.



Relative Humidity (%)

Relative humidity (RH) is the ratio of the amount of water vapor in the air to the amount of water vapor that the air could hold at the specific temperature and pressure.



Air Velocity (ft/s)

According to ANSI/ASHRAE Standard 55, it is the average speed of the air to which the body is exposed, with respect to location and time. Effective air flow increase the rate of evaporation of sweat and removal of heat from the body.



Metabolic Rate (met)

The rate at which we generate heat (our metabolic rate) depends mostly upon our level of muscular activity, partly upon what we eat and drink. This analysis uses a set metabolic rate of 58.2 - seated at rest.



Clothing Insulation (clo)

The amount of thermal insulation worn by a person has a substantial impact on thermal comfort, because it influences the heat loss and consequently the thermal balance. This analysis uses a set clothing insulation value of 0.5 clo which is equivalent to trousers and short-sleeved shirt, respectively.

Figure 31. The six main factors in thermal comfort.

Source: *Mechanical and Electrical Equipment for Building*, redrawn by author

7.2 Metric: Predicted Man Vote (PMV)

ASHRAE Standard 55 recommends the Analytical Comfort Zone Method using the 7-point PMV/PPD -based thermal sensation scale, also known as the heat balance

approach, to determine acceptable thermal comfort.⁹⁴ The Predicted Mean Vote (PMV)/Predicted Percentage of Dissatisfied (PPD) model stands among the most recognized thermal comfort models to date as it considers both individual and environmental factors. This model, developed by P.O. Fanger, was developed using principles of heat balance and experimental data based on observation of human subjects in an atmospheric controlled environment under steady conditions.

The PMV model represents the predicted mean response of a large group of people where thermal sensation is dependent on individual and environmental factors. The six main factors (air temperature, mean radiant temperature, relative humidity, air velocity, metabolic rate, and clothing insulation) are taken into account and are the main performance indicator for this model. Hourly conditions are calculated producing a number that falls on a thermal sensation scale. The scale ranges between -3 to +3 where 0 is considered thermally neutral.

⁹⁴ (ASHRAE 2013)

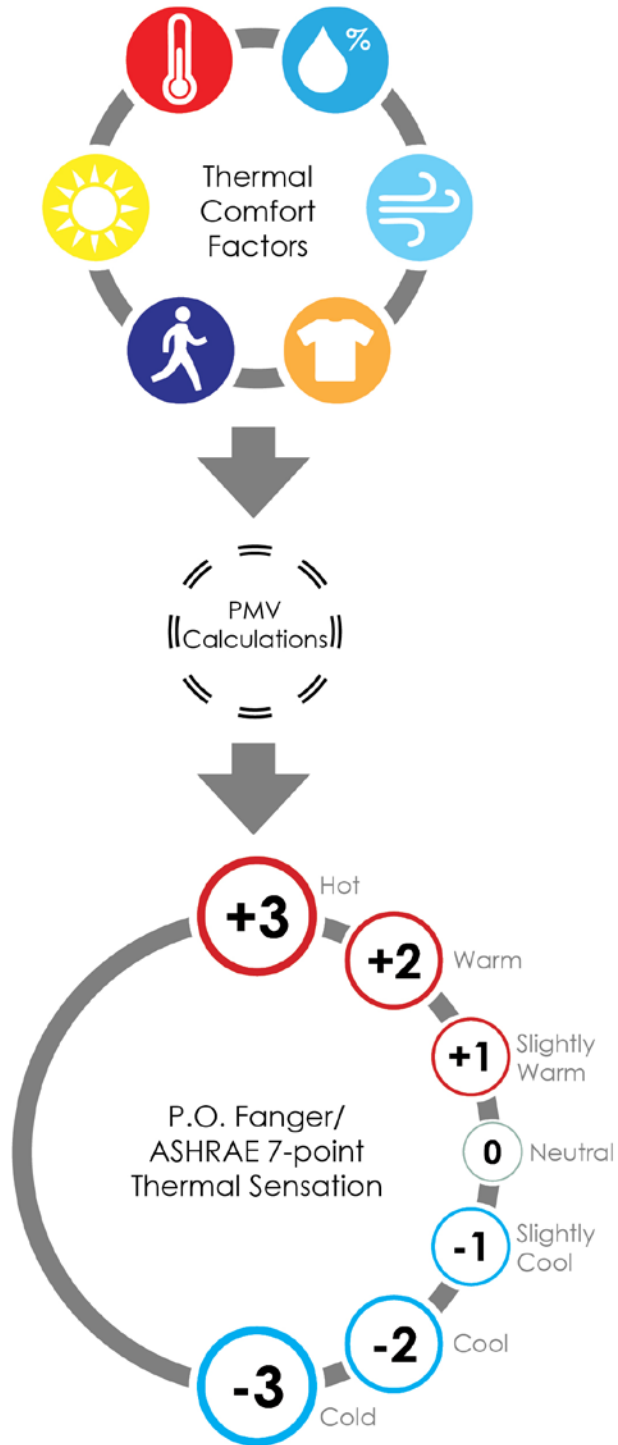

Figure 32. Hourly conditions are calculated producing a number that falls on the predicted mean vote (PMV) thermal sensation scale.

Source: Drawn by author

The PPD represents a percentage of a large group of people that would be dissatisfied relative to PMV. PMV can be represented as a curve in conjunction with PPD, where PPD increases when PMV moves further away from 0 defined as a neutral in terms of thermal sensations, illustrated in figure 33. The model uses a 7-point scale (-3, -2, -1, 0, +1, +2, +3) of which correlates with thermal sensation. PMV -3 indicates a “cold” thermal sensation. In contrast, PMV +3 indicates a “hot” thermal sensation, and 0 being thermally neutral. Values in between range from “cool,” “slightly cool,” “slightly warm,” and “warm.” Although 0 is considered thermally neutral; the PMV curve illustrates a minimum of 5% dissatisfied persons. In other words, not everyone is satisfied under similar conditions.

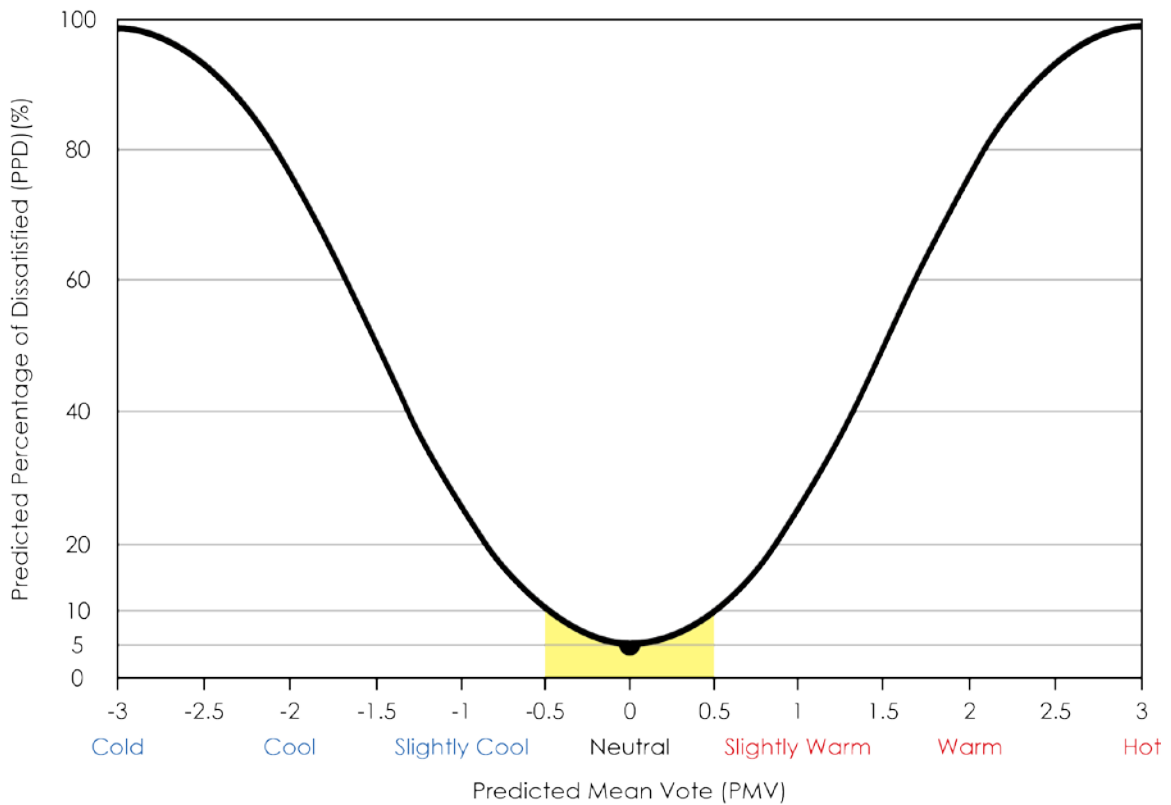

Figure 33. Predicted Mean Vote relative to Predicted Percentage Dissatisfied

Source: A Review of General and Local Thermal Comfort Models for Controlling Indoor Ambiences, redrawn by author.

Standards such as ASHRAE describe acceptable thermal comfort as a range between a predicted mean vote of -0.5 and +0.5 (highlighted in figure 33) on the

thermal sensation scale, maximum 10% dissatisfied persons as demonstrated on the PMV/PPD curve. A PMV below -0.5 and/or above +0.5 would otherwise be considered uncomfortable. The PMV/PPD model and thermal comfort zone was based on occupant's thermal sensations in a climate controlled environment. As a result, this model is limited to occupants in air conditioned spaces.

Researchers have found occupants in naturally ventilated spaces are more likely to go through acclimatization. Acclimatization refers to the "long-term responses of an organism to changes in its environment."⁹⁵ This was further investigated in a study where those occupying a naturally ventilated building were found to be more tolerable to temperature swings than those occupying fully air conditioned spaces.⁹⁶ Researchers have linked psychological factors, such as people's expectations to the variations of the natural environment, to the expansion of the prescribed thermal comfort zone of air conditioned spaces.⁹⁷

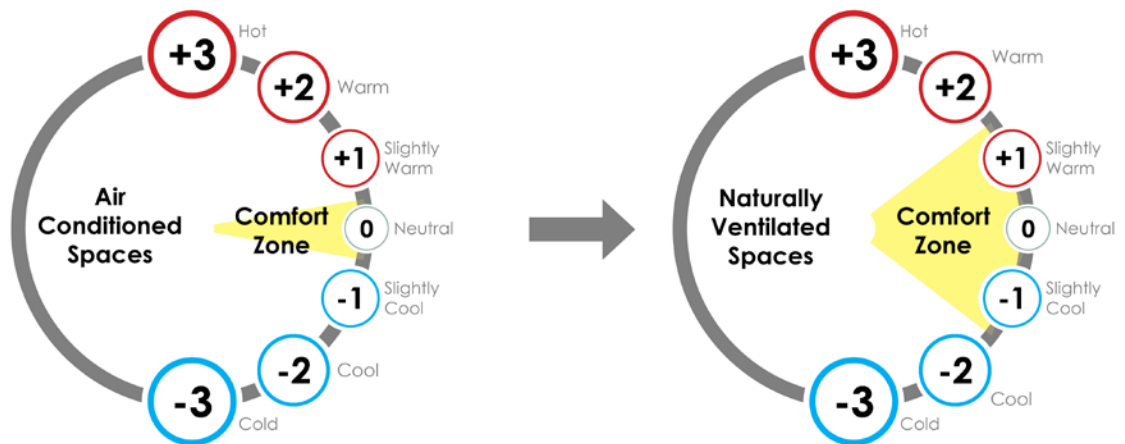

Figure 34. Thermal comfort zone in air conditioned spaces versus naturally ventilated spaces relative to thermal sensations of the predicted mean vote model. Note that the comfort zone in naturally ventilated spaces illustrated above is an estimation based on one's ability to accept a wider range of thermal sensations and environment conditions. There is not a large body of knowledge of how the PMV model relates to naturally ventilated spaces and what the thermal comfort zone range is.

Source: Drawn by author

⁹⁵ (Britannica 2015)

⁹⁶ (Brager and de Dear 2001)

⁹⁷ Ibid

The adaptive thermal comfort (ATC) model was developed for measuring thermal comfort in naturally ventilated spaces by applying “the indoor operative temperature in relation to the outdoor air temperature as the main performance indicator.”⁹⁸ This in theory accounts for the psychological factor that expands the thermal comfort zone. Although the ATC model accounts for the physiological factor in thermal comfort the main performance indicator is limited to air temperature while the PMV model accounts for other environmental factors such as mean radiant temperature and relative humidity. Humidity is an important factor in thermal comfort especially for naturally ventilated spaces residing in hot and humid climates. Also, the ATC model is currently only applicable to office typologies.⁹⁹ This was not the case for this project which looks at thermal comfort in residential typologies in a hot and humid climate. The PMV model was chosen as the metric in determining acceptable thermal comfort of the three spatial configurations as it offered “larger flexibility and wider applicability” in comparison to the adaptive thermal comfort model. Most importantly it was able to account for other environmental factors in the tropics such as humidity.¹⁰⁰ The model also provides insight on the thermal sensations experienced within each tested configuration model.

There is not a tremendous amount of knowledge of how the PMV model relates to naturally ventilated spaces therefore the comfort zone or threshold used to measure comfort in each spatial configuration model was estimated to reflect one’s ability to accept a wide range of temperatures and environmental conditions. The estimated thermal comfort results of each spatial configuration were not seen as absolute (predicted) but relative (comparative) to the conditions being tested.

This project utilized predicted mean vote as a metric determining the amount of occupied hours within a year (8766 hrs.) exceeding an upper threshold of +1.5. A PMV exceeding +1.5 would be considered uncomfortable. The location in which this analysis takes into account rarely experiences thermal sensations below -1.5 (“slightly cool-cool”) and so it was not a major contributor to thermal discomfort. Thermal discomfort in this case falls on the warmer side of the thermal sensation scale. The predicted percentage of dissatisfied relative to the newly defined PMV thermal comfort threshold became

⁹⁸ (Linden, Loomans and Hensen 2008)

⁹⁹ Ibid

¹⁰⁰ Ibid

rather arbitrary and thus was not part of the main focus of this analysis as it was more comparative than predicted.

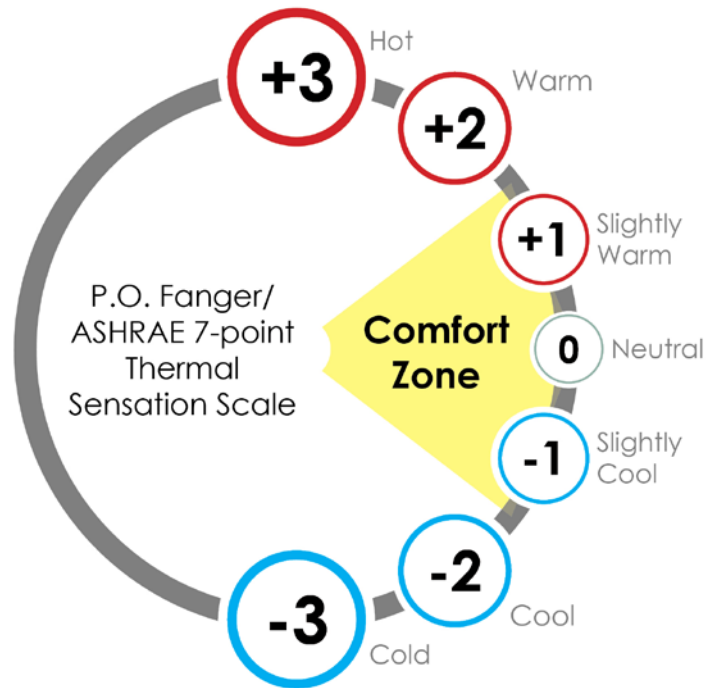

Figure 35. Estimated predicted mean vote (PMV) thermal comfort zone ($-1.5 < \text{comfort} < +1.5$) used for the analyses in determining acceptable thermal comfort in the three naturally ventilated configuration models.

Source: Drawn by author

7.3 Simulation Modeling

There does not seem to be an existing body of knowledge that tests the thermal comfort conditions of a skip-stop double loaded corridor configuration. Without field validation of existing precedents like Unité d'Habitation, the absolute magnitude of variables is nearly impossible to measure. Therefore, this project utilized simulation modeling to obtain good estimates on the thermal comfort outcome of three spatial configurations.

There are several types of simulation modeling that are able to provide thermal comfort data of a space. "Design performance modeling (DPM) informs design decisions by predicting a buildings performance with respect to energy efficiency,

daylight penetration, glare control, thermal comfort, natural ventilation, and similar factors.”¹⁰¹ DPM can be very beneficial for building designers during the early stages of the design process relative to other types of modeling.

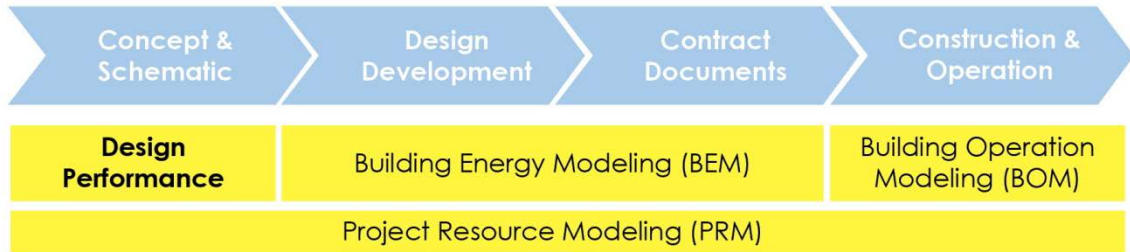

Figure 36. Types of modeling relative to design processes. This project utilized Design Performance Modeling (DPM) typically taken place during concept and schematic design stage.

Source: *Architect’s Guide to Integrating Energy Modeling in the Design Process*, redrawn by author.

There are two main modeling tools when looking at natural ventilation and thermal comfort – bulk air flow and computational fluid (CFD) dynamic modeling. These two produce very distinctive outputs but the combination of the two can give building designers a better prediction on the outcomes of their design decisions relative to natural ventilation and thermal comfort. This project utilized both bulk air flow and computational fluid dynamic modeling to investigate the thermal comfort conditions of three spatial configuration models.

Bulk air flow modeling is not found in many building simulation software’s today but the tool allows for annual analysis of airflow effects on heat transfer and comfort. Therefore, it is very suitable for simulations on natural ventilation relative to thermal comfort. More importantly, it utilizes the PMV model taking into account the 6 main factors in determining thermal comfort. Bulk air flow modeling is limited in some ways in that it does not recognize high air speeds as a nuisance which is why CFD modeling was used.

Computational fluid dynamic (CFD) modeling uses algorithms and calculations to simulate the interactions of liquid and gases.¹⁰² This type of method allows for a high degree of accuracy, however, its results are limited to a point-in-time (PIT). This type of

¹⁰¹ (AIA 2012)

¹⁰² Ibid

modeling, different from the numerical output produced from bulk air flow modeling, produces visual outputs – a section perspective of a space with the resulting air flow. The intent of using CFD modeling was to visually investigate the air flow patterns associated with each tested model as to further understand the effects of spatial geometry and configuration on natural ventilation and thermal comfort. CFD modeling was also used to visually measure high air speeds that bulk air flow modeling was not able to recognize as a nuisance. It should be made clear that CFD visual results, due to its output limitations, were not seen as conditions that occur year-round but rather a point-in-time.

7.4 Software Tools

Each spatial configuration was modeled in Google SketchUp (2012 version). The 3D modeling software provides tools for a quick and easy construction process. Solid walls were differentiated from windows. Fenestration or window-to-wall ratios of each model are further explained in chapter 8.5. Box shading devices with three projection factors were also created for the parametric analysis which is further explained in chapter 10.1.2. These models were then imported into separate software for simulations on building performance.

Simulations were conducted using the Integrated Environmental Solutions (IES) Virtual Environment software (2014 version). It includes various simulation tools – thermal simulations, solar shading analysis, day lighting analysis, life cycle analysis, etc. – to assess a building's environmental performance and inform design. The software provides a dynamic thermal simulation engine called Apache to simulate occupant thermal comfort based on various model inputs such as annual hourly weather data, building geometry and construction, glazing ratios, façade openings, shading, and internal loads. Model inputs used throughout the bulk air flow analyses are further explained in chapter 8. PMV was among the various outputs that Apache produces making it ideal for bulk air flow modeling taking into account the six major factors of thermal comfort.

Computational fluid dynamic modeling (CFD) was conducted within the same software but under a different tool called Micro Flow. As with any CFD tool the main model inputs included spatial geometry and window opening areas. The visual results illustrate the air flow patterns associated with each spatial configuration. A parametric

analysis was conducted with the CFD model tool investigating the effects of various windows opening area on air flow.

Ecotect Analysis Weather Tool (2011 version) was utilized for its ability to provide graphical information on climate conditions such as psychrometric charts, sun path diagrams, wind roses, etc. The climate data was obtained from a standard typical meteorological year (TMY) file. The same file was utilized for the simulations in IES Virtual Environment.



Figure 37. Software used for this analysis.

7.5 Location of Analysis

The city of Honolulu, Hawaii was chosen as the location for this analysis. It is the largest city in Hawaii with a land area of roughly 68.4 square miles and is home to 390,738 people as of 2010. It is the state's center of political, commercial, industrial, and cultural activities of which tourism is a largest contributing factor to the economic growth of the city as well as the rest of Hawaii. The Kaka'ako district of Honolulu is currently undergoing redevelopment as construction for many high rises are being planned in the next two decades. Considering the increase in construction of high rises in the state, this project provides a design model baseline for future tall buildings in Honolulu (and other hot and humid cities) as its climate is suited for natural ventilation.

Hawaii's climate varies by regions and islands of which 11 of the 13 world climates can be found throughout the state.¹⁰³ Therefore, weather data is very important when designing in Hawaii as conditions in one location can be very different in another location not too far away. This analysis utilized the weather data via a typical meteorological year (TMY) file obtained from the Honolulu International Airport. The data file is a TMY3, 3 meaning 30 years of collected data. Figure 38 provides a breakdown of

¹⁰³ (Paiva 2015)

the monthly conditions that occur in this location based on data provided by the weather file read by Ecotect Analysis Weather Tool (2011 version).

Honolulu Annual Weather Data				
<u>Month</u>	<u>Average Temp (F)</u>	<u>Maximum Temp (F)</u>	<u>Average Humidity (%)</u>	<u>Average Air Speed (ft/s)</u>
Jan	72	85	57	14
Feb	73	83	63	15
Mar	74	86	57	14
Apr	75	85	52	16
May	77	87	55	17
Jun	78	85	55	17
Jul	80	90	54	18
Aug	81	90	52	17
Sept	80	92	58	18
Oct	79	92	56	18
Nov	76	87	59	17
Dec	74	86	60	14

Figure 38. Honolulu average monthly environmental conditions based on the Honolulu International Airport Typical Meteorological Year (TMY) 3 weather data file. All simulations were conducted using the data seen above.

Source: Ecotect Analysis 2011 Weather Tool, Honolulu International Airport TMY3 weather file

According to the weather data, the climate of this location is classified as “warm humid” when overlaid onto a psychrometric chart as seen in figure 39. The psychrometric chart for Honolulu graphs the thermodynamic parameters of air in its location taking into account dry-bulb temperature, wet-bulb temperature, dew point, relative humidity, humidity ratio, and enthalpy. It is clear that the climate conditions in Honolulu are relatively steady throughout the year.

Psychrometric Chart

Location: Honolulu Intl Arpt, USA
Frequency: 1st January to 31st December
Weekday Times: 00:00-24:00 Hrs
Weekend Times: 00:00-24:00 Hrs
Barometric Pressure: 101.36 kPa
© Weather Tool
Climate Classification

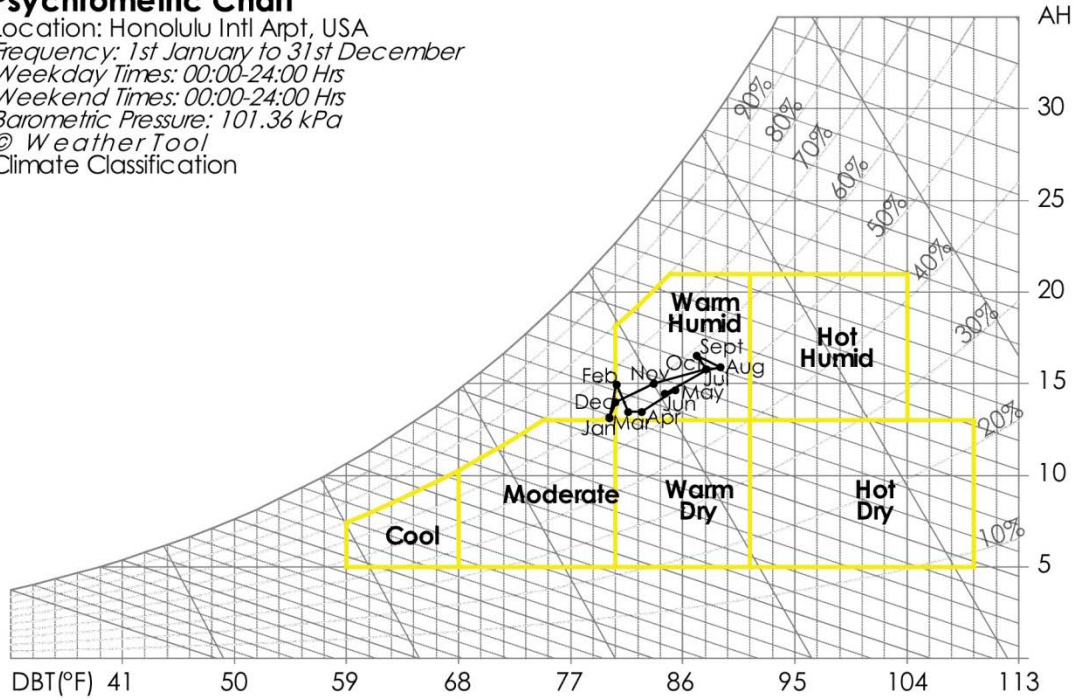

Figure 39. Honolulu’s annual weather data represented on a psychrometric chart. Based on the Honolulu’s weather data the climate is classified as “Warm Humid” according to the chart.
Source: Ecotect Analysis 2011 Weather Tool, Honolulu International Airport TMY3 weather file

Warmer conditions that occur between July and October months require air conditioning to offset thermal discomfort due to high air temperature and humidity. However, in most cases air conditioning is used year-round despite outdoor conditions being relatively close to indoor conditions during other times of the year. As a result, roughly 43% of building energy consumption in Hawaii is dedicated toward cooling and HVAC fans as seen in figure 40.

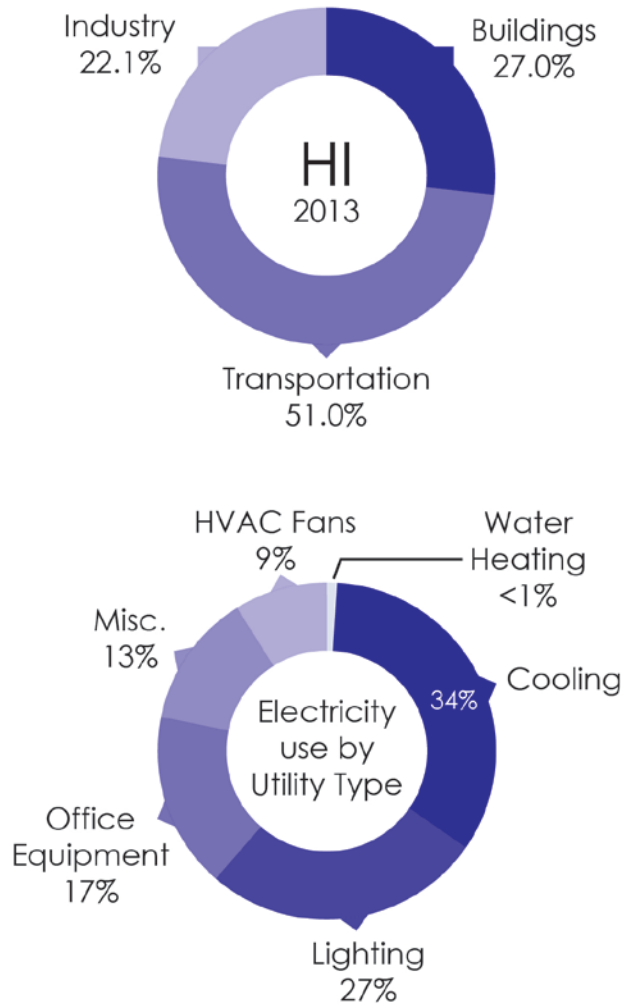

Figure 40. Energy consumption in Hawaii (2013)
 Source: Hawaii State Energy Office, redrawn by author

When the monthly conditions seen in figure 39 are broken down into hourly data, represented as points, we can see that the outdoor conditions experienced in Honolulu do exceed the designated comfort zone, represented as a yellow outline on the psychrometric chart in figure 41. This zone was produced by ASHRAE, representing the combinations of " air temperature and relative humidity that most often produce comfort for a seated North American adult in shirtsleeves (0.6 CLO) in the shade and without

noticeable air motion.”¹⁰⁴ Ecotect Analysis Weather Tool automatically generates the comfort zone based on these standards.

Figure 41 illustrates that air conditioning would be required to provide thermal comfort in this climate for most of the year thus contributing to high building energy consumption. However, with air movement through the use of natural ventilation this comfort range is expanded and thus able to compensate for the high air temperatures and humidity represented as a blue outline. ASHRAE 55 notes that an expanded comfort range applies only to spaces with no air conditioning. The primary mode of comfort in this case would be operable windows.

Acclimatization comes to mind as researchers have found those residing in naturally ventilated spaces are more tolerable to higher air temperatures and humidity as their body adjust to the external fluctuating climatic conditions thereby expanding the thermal comfort zone. Natural ventilation cooling is an effective passive solution to aid in thermal comfort in hot and humid conditions as higher air speed is used to offset high air temperatures and increase evaporation of sweat.¹⁰⁵ This potentially lessens the need for air conditioning and reduces building energy consumption while continuing to provide thermal comfort for most of the year.

Another factor in expanding one’s thermal comfort is psychological based. By providing operable windows or ceiling fans in a naturally ventilated space provides occupants personal control of their own thermal environment thus expanding the thermal comfort zone. Limiting occupant control of indoor environments such as traditional office spaces narrows the thermal comfort zone as can be seen in the PMV model. Two of these actions – various window opening areas and local air speeds – are tested through a series of parametric analyses to investigate their effectiveness in improving thermal comfort.

¹⁰⁴ (Grondzik, et al. 2010)

¹⁰⁵ Ibid

Psychrometric Chart

Location: Honolulu Intl Arpt, USA
Data Points: 1st January to 31st December
Weekday Times: 00:00-24:00 Hrs
Weekend Times: 00:00-24:00 Hrs
Barometric Pressure: 101.36 kPa
© Weather Tool
Comfort: Natural Ventilation

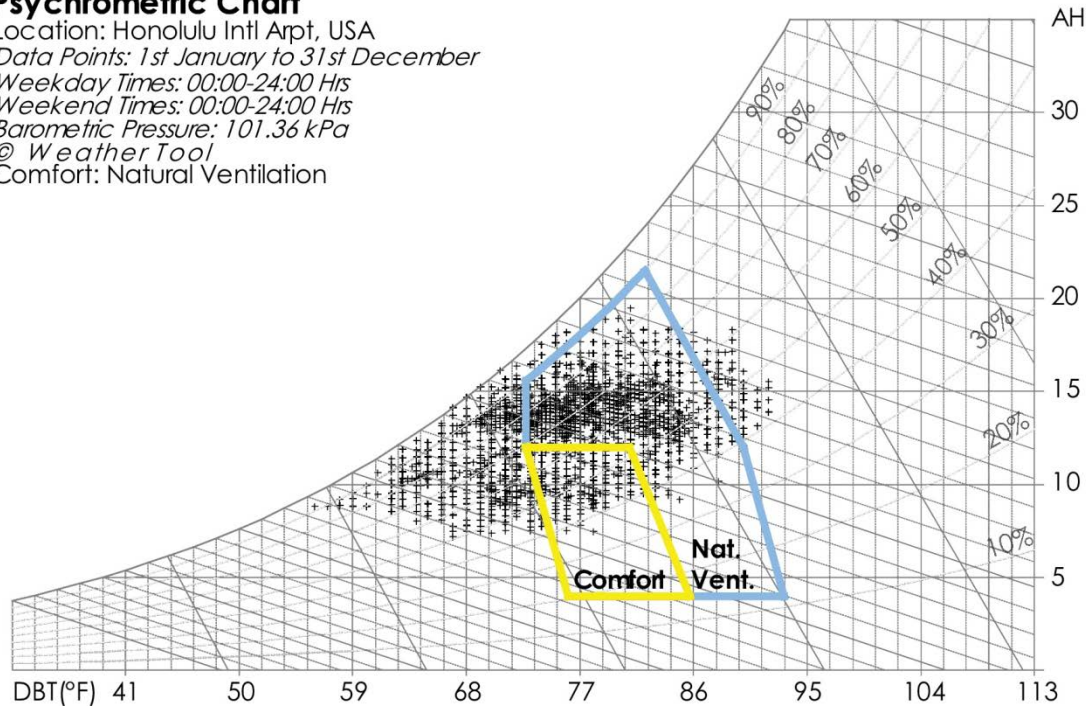

Figure 41. Psychrometric Chart of Honolulu's climate hourly conditions, represented as points, overlaid with the standard thermal comfort zone developed by ASHRAE. Note when natural ventilation is applied the thermal comfort zone expands compensating for higher air temperatures and humidity as a result.

Source: Ecotect Analysis 2011 Weather Tool, Honolulu International Airport TMY3 weather file

Beyond air temperature and humidity, other climatic factors were considered such as orientation relative to sun and wind. These factors play a major role in thermal comfort as higher solar radiation and wind speeds associated with Honolulu's location can contribute to discomfort both thermally and psychologically (higher air speeds being a nuisance). Each model developed for this analysis attempts to address these factors in a strategic manner to reflect design principles found in tropical vernacular architecture – minimizing heat gain and maximizing ventilation.

CHAPTER 8

Simulation Models and Inputs

This chapter explains in further detail the models developed for the simulations. Two baseline models – double loaded corridor (DLC) and single loaded corridor (SLC) – were created in order to assess the improved thermal comfort of a skip-stop double loaded corridor spatial (SSDLC) model, totaling 3 models. Beyond the basic geometry of each model, this chapter also explains the models orientation and immediate location relative to a hypothetical building mass which it resides in as well as their building envelope design.

8.1 Orientation and Immediate Location Relative to Sun and Wind

Each model was placed in hypothetical building mass. These building masses attempt to acknowledge Honolulu's climate characteristics – high solar radiation and wind speeds – by means of strategic orientation to sun and wind similar to that addressed in traditional vernacular designs found in the tropics. The elongated hypothetical building masses were oriented with short faces toward east/west. This orientation is ideal in Honolulu as it minimizes solar heat gain by reducing low sun angle exposure and providing the best shading opportunities along south facades.¹⁰⁶ The use of shading devices (horizontal overhangs) can reduce high solar radiation along the south façade caused by low sun angles during the winter.¹⁰⁷

¹⁰⁶ (DBEDT 2001)

¹⁰⁷ Ibid

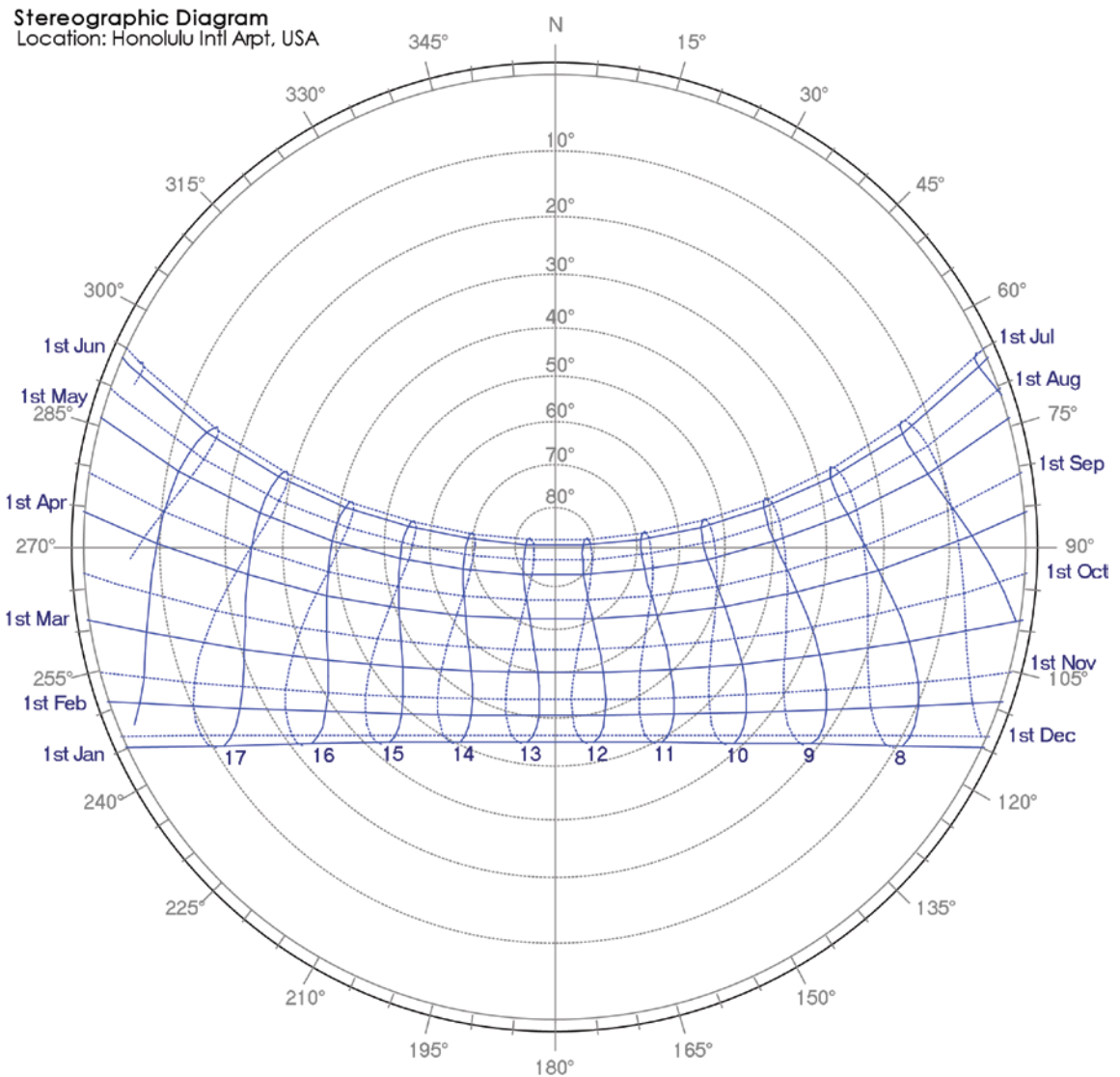

Figure 42. Honolulu's sun path diagram illustrating the sun's seasonal and hourly position in the sky.
Source: Ecotect Analysis 2011 Weather Tool, Honolulu International Airport TMY3 weather file

Units that would otherwise be located at corners/ends (oriented east/west) and top floor were not tested. The effects of strong solar radiation associated with these units would have greatly affected the thermal comfort conditions in comparison to those that are buffered by surrounding units. These effects can be mitigated with increase insulation and thermal mass. However, modification to the building construction material was not the intent of this project. Units that are located at the center of the hypothetical building mass were chosen for this analysis as they would provide more consistent data outputs. Figures 43, 44, and 45 illustrate the locations of the tested units relative to

orientation in its given hypothetical building mass. Each model had a north and south facing unit for the exception of the single loaded corridor (SLC) model due to its spatial configuration. Each unit in every model had no internal vertical barriers (walls or partitions) for the exception of those adjacent to the access corridors in the double loaded corridor (DLC) and skip-stop double loaded corridor (SSDLC) configurations.

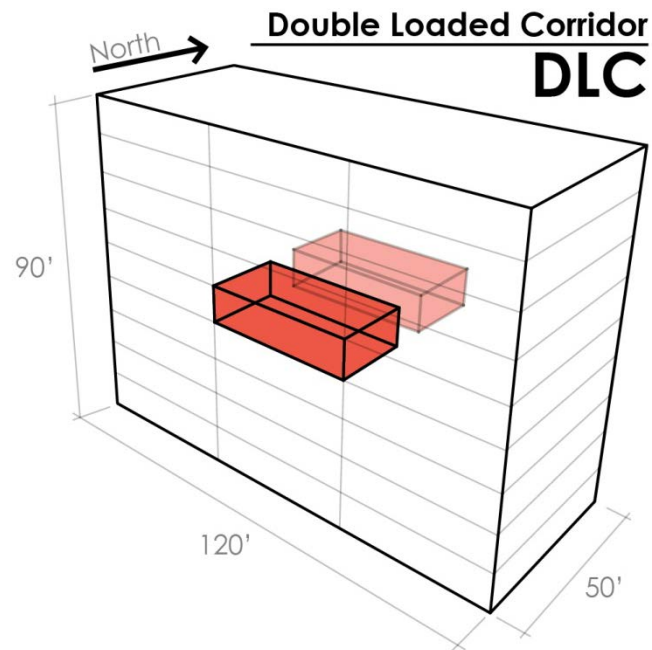

Figure 43. Double loaded corridor building model and orientation.

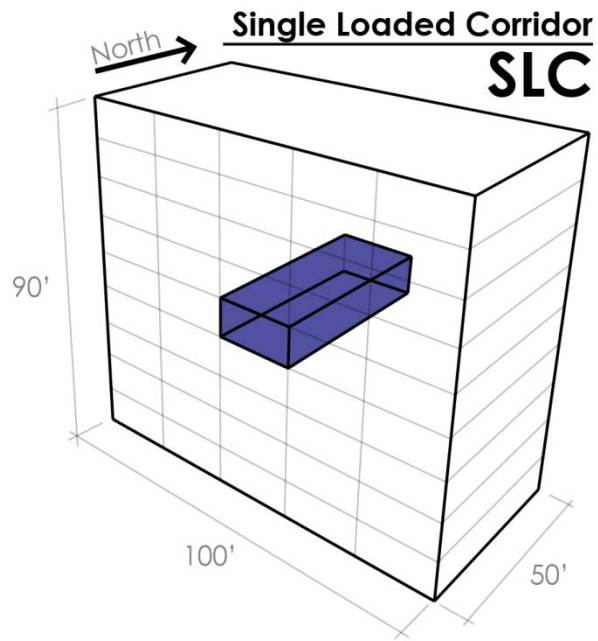

Figure 44. Single loaded corridor building model and orientation.

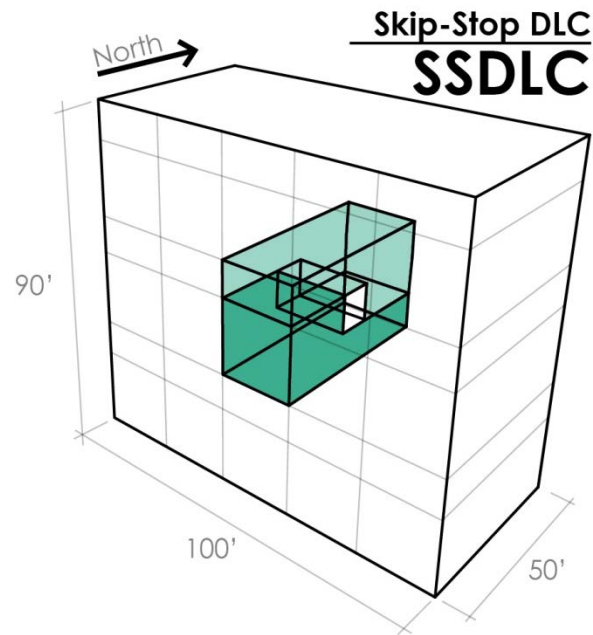

Figure 45. Skip stop double loaded corridor building model and orientation

The orientations of these building masses are not only ideal for minimizing solar heat gain but also maximizing air flow and ventilation as it takes advantage of Honolulu's predominant north-east and east-north-east trade winds. The wind rose, figure 46,

illustrates wind direction relative to speed and yearly occurrence displayed in hours. DBEDT recommends orienting a space with openings on opposite walls 45 degrees from the predominant wind direction.¹⁰⁸ The resulting orientation relative to wind direction is said to improve air flow by 20%. Each tested model is oriented in a similar manner with their façade facing 45 degrees to the north-east and east-north-east prevailing winds. Orientation of each model was fixed throughout the bulk air flow and CFD analyses.

¹⁰⁸ (DBEDT 2001)

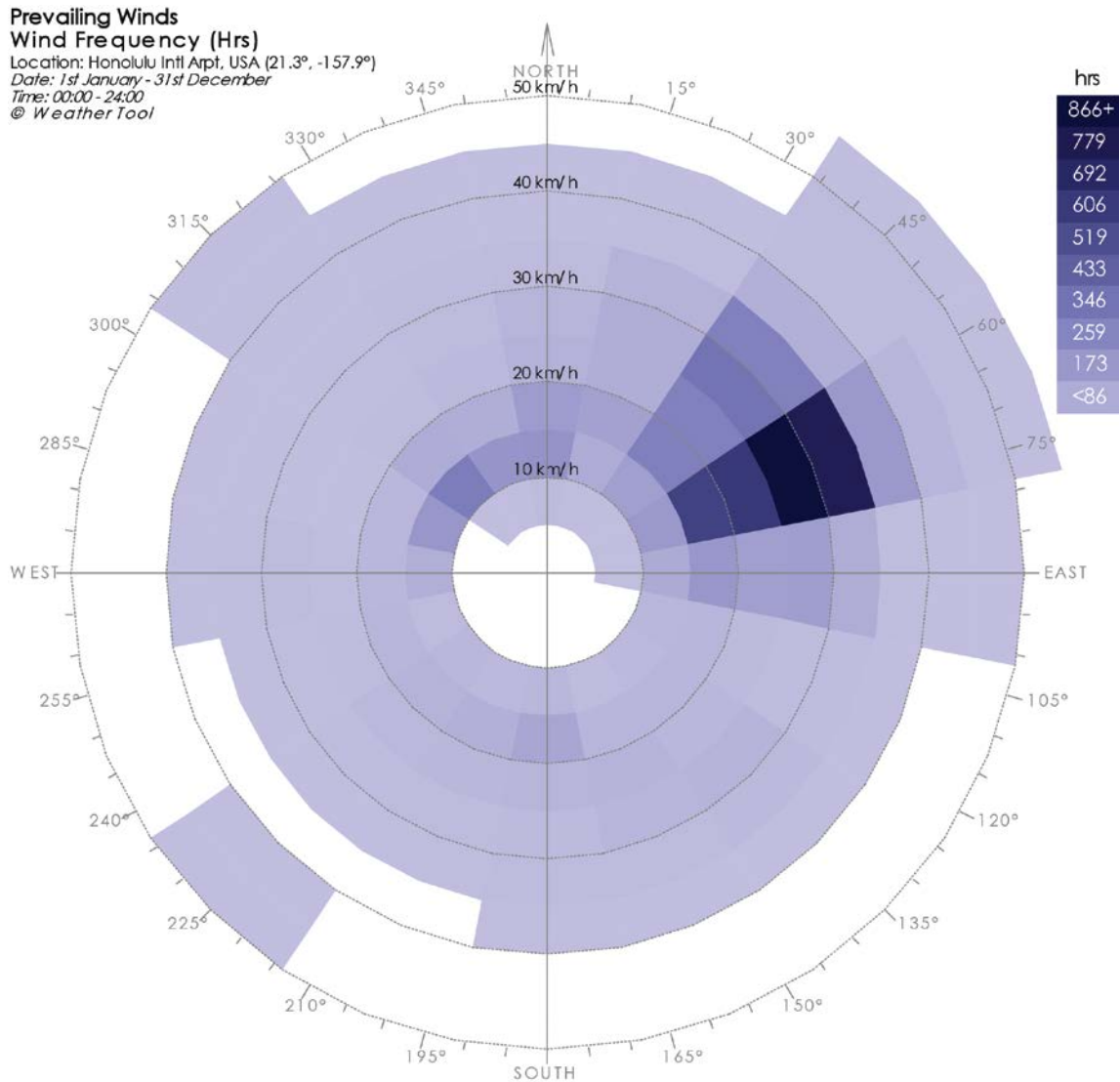

Figure 46. Wind rose of Honolulu illustrating the wind speed relative to direction and hourly occurrence throughout the course of the year.

Source: Ecotect Analysis 2011 Weather Tool, Honolulu International Airport TMY3 weather file.

There are times during the year Honolulu experiences high air speeds that exceed comfort. Careful consideration towards the building envelope design was done to help mitigate these conditions. This was further investigated with computational fluid dynamic modeling which provided a visual understanding of how extreme the effects of various window openings on internal air flow and comfort, since bulk air flow modeling does not consider high air speeds as a nuisance.

8.2 Double Loaded Corridor

The double loaded corridor (DLC) is a common spatial configuration derived from temperate climate models where units are placed alongside of a central access corridor. As a result of this configuration, units are only able to provide single-sided ventilation (for the exception of corner units) as the corridor acts as an internal barrier to cross ventilation. Single-sided ventilation, defined as one or more openings at a single façade of a closed room or building, is limited to pressure differences along that one façade.¹⁰⁹ Generally, natural ventilation performs better when pressure difference is much higher as in the case of double-sided or cross ventilation.¹¹⁰

Due to the limitation of single-sided ventilation, units generally residing in a DLC configuration will resort to the use of air conditioning for cooling and ventilation. Despite the disadvantage in passive ventilation, this spatial configuration remains popular for its efficiency in space planning. Optimizing unit count per floor in a high-density building is one of the main factors that contribute to the popularity of this spatial configuration in up and coming high-rise buildings.

This spatial configuration was chosen as a baseline model for the analyses as to demonstrate the limitations of single-sided ventilation relative to double-sided ventilation models. ASHRAE 62.1 Ventilation for Acceptable Indoor Air Quality (IAQ) prescribes a maximum room depth two times the ceiling height for single-sided naturally ventilated spaces.¹¹¹ The double loaded corridor model developed for the analyses follows this criterion as illustrated in figure 47. There were no internal obstructions in this model for the exception of the centralized access corridor that run between north and south facing units.

¹⁰⁹ (Mohamed, et al. 2011)

¹¹⁰ Ibid

¹¹¹ (ASHRAE 2013)

DLC Double Loaded Corridor

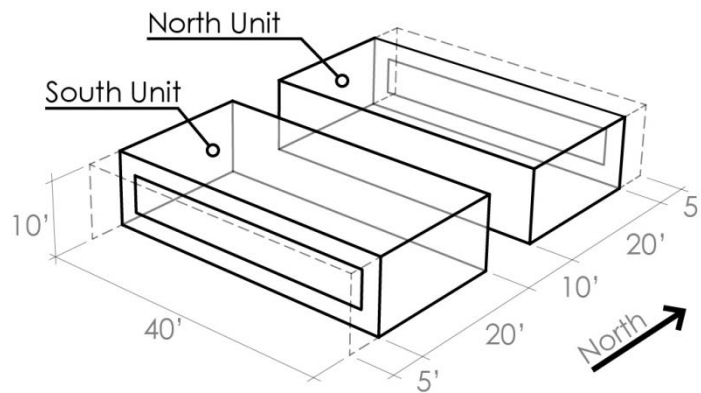

Figure 47. Double Loaded Corridor (DLC) model developed for the analyses. The depth of the space is no more than two (2) times the ceiling height as prescribed by ASHRAE.

8.3 Single Loaded Corridor

The single loaded corridor (SLC) is a spatial configuration found in hot and humid climates where units are placed alongside an external access corridor. As a result of this configuration, units are able to provide double-sided or cross ventilation. Providing two openings on opposite sides of the space allows for manipulation of pressure differences along two facades thus performing well for natural ventilation. Less common than the DLC, the SLC configuration was chosen for this investigation because of its ability to provide efficient cross ventilation for improved thermal comfort.

ASHRAE 62.1 Ventilation for Acceptable Indoor Air Quality (IAQ) prescribes a maximum room depth five times the ceiling height for double-sided naturally ventilated spaces.¹¹² The single loaded corridor model developed for this analysis follows this criterion as illustrated in figure 48. The resulting width of the space, 50'-0" from opening to opening, matches with the width of the DLC building model which was intentionally done to ensure performance outputs of each model could be realistically compared.

¹¹² (ASHRAE 2013)

SLC Single Loaded Corridor

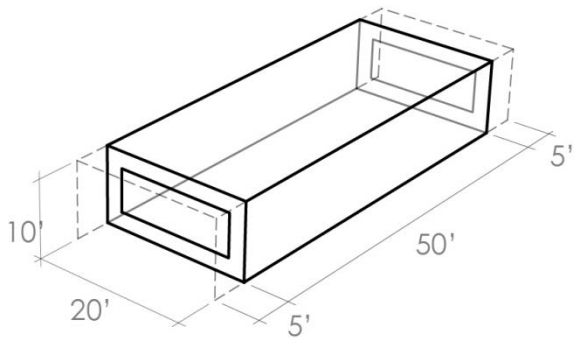

Figure 48. Single Loaded Corridor (SLC) model developed for the analyses. The depth of the space is no more than five (5) times the ceiling height as prescribed by ASHRAE.

8.4 Skip-Stop Double Loaded Corridor

The skip-stop double loaded corridor (SSDLC) is not a very common spatial configuration. It was first developed by Le Corbusier most famously seen in his series of apartment complex buildings called Unité d’Habitation throughout Europe. There are very few buildings that utilize the SSDLC configuration in hot and humid conditions. Granted, there are a few buildings in Honolulu that were inspired by this configuration (e.g. the Ala Wai Plaza designed with a skip-stop *single* loaded corridor) but none take the form of a double loaded corridor. Due to the lack of this configuration in a tropical setting, there is very little knowledge on the thermal comfort conditions of such spaces.

One could think of the SSDLC configuration as a combination of both the DLC and SLC configuration. The configuration allows for two-level units to be placed alongside a central access corridor while simultaneously providing double-sided or cross ventilation. A building with this configuration only requires a corridor and lift (elevator) at every other floor hence the term “skip-stop.”¹¹³ This spatial configuration was chosen for this investigation due to its ability to not only provide efficient cross ventilation but space planning with fewer access corridors and increase usable floor area per unit. Its geometry, providing a double height ceiling space, also has the potential to provide

¹¹³ Ibid

buoyancy-driven ventilation aka stack-effect that could aid in passive cooling especially on days with little to no wind-driven ventilation.

The SSDLC model developed for this analysis shares some similarities with the DLC and SLC models as illustrated in figure 49. This was also intentionally done to ensure performance outputs of each model could realistically be compared to the other two baseline models. The corridor level of the model resembles the spatial dimensions of the DLC configuration with the width between openings and corridor being 20'-0" while the other level resembles that of the SLC model having double-sided ventilation.

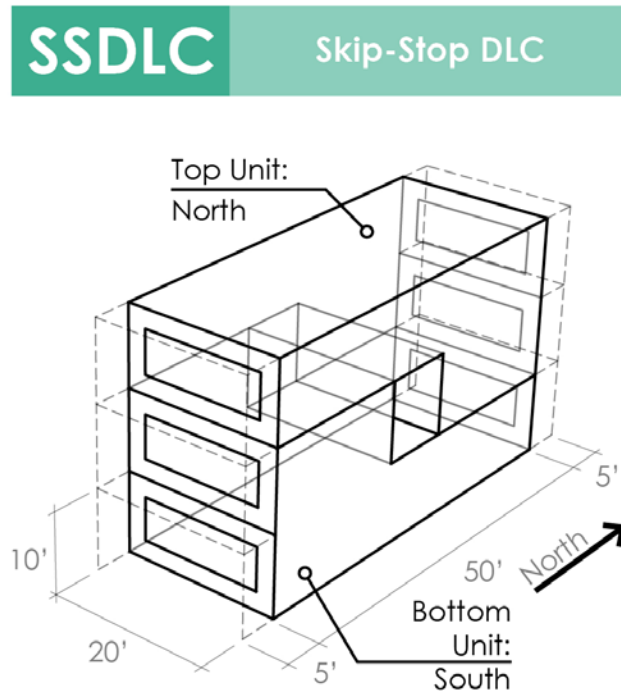

Figure 49. Unité d'Habitation inspired Skip-Stop Double Loaded Corridor (SSDLC) model developed for the analyses. The model shares some similarities with the DLC and SLC models. The big difference is the double height ceiling spaces produced from the geometry relative to the access corridor that could aid in buoyancy-driven ventilation.

8.5 Building Envelope Design and Variables

To further ensure each configuration model could be realistically compared, they were assigned the same building envelope and construction materials as seen in figure 50. The building envelope was developed using standards and guidelines such as the

International Energy Conservation Code (IECC) and International Building Code (IBC). Internal partitions refer to the walls that buffer between units in the hypothetical building mass. Insulation in these walls was defaulted for acoustic and privacy purposes, not thermal. External walls were based on traditional building construction utilizing insulation with a high R-value and 40% fenestration ratio in accordance with the IECC 2015.

Building Envelope, Construction Materials	
Solid Wall Assembly	R-13, steel framing @ 16 in. OC w/ insulation
Internal Partition Assembly	steel framing @ 16 in. OC with insulation
Internal Ceiling/Floor Assembly	4 in. light weight concrete floor deck
Glazing SHGC	0.40
Glazing U-Value	0.95, single-glazed
Glazing (Fenestration) Ratio	40% (10%, 25%, 60% opening areas)
External Shading P.F.	0, 0.33, 0.66
Comfort Parameters	
Air Temp (F)	
Men Radiant Temp (F)	Honolulu International Airport
Humidity (%)	TMY3 Weather Data File
Air Velocity (ft/s)	
Clothing Insulation (clo)	0.5 - "casual summer clothing"
Metabolic Rate (met)	58.2 - seated at rest
Internal Heat Loads	
Occupancy (people)	2 (400 sqft/person)
Equipment	0
Lighting	1 W/sqft

Figure 50. Building envelope design and model inputs for each configuration.

Majority of the model inputs seen in figure 50 were fixed throughout the analyses for the exception of three highlighted variables – external shading device projection factor (PF), window opening area, and internal local air speeds. These factors were manipulated through a series of parametric analyses to investigate how effective they were on thermal comfort in the naturally ventilated models.

Projection factor is determined by dividing the horizontal distance of an overhang by the vertical distance between the window sill to the underside of that overhang. Figure 51 provides an illustration of the projection factors used for the single loaded corridor model. Based on the building envelope design for each model, a projecting factor of 0.33 equates to 2'-6" overhang and 0.66 equates to 5'-0" overhang. Using a model with a projection factor of 0 (shade-less) as a baseline, each configuration was assigned these projection factors to measure the effects of shading on thermal comfort. The same projection factors were used on the DLC and SSDLC models.

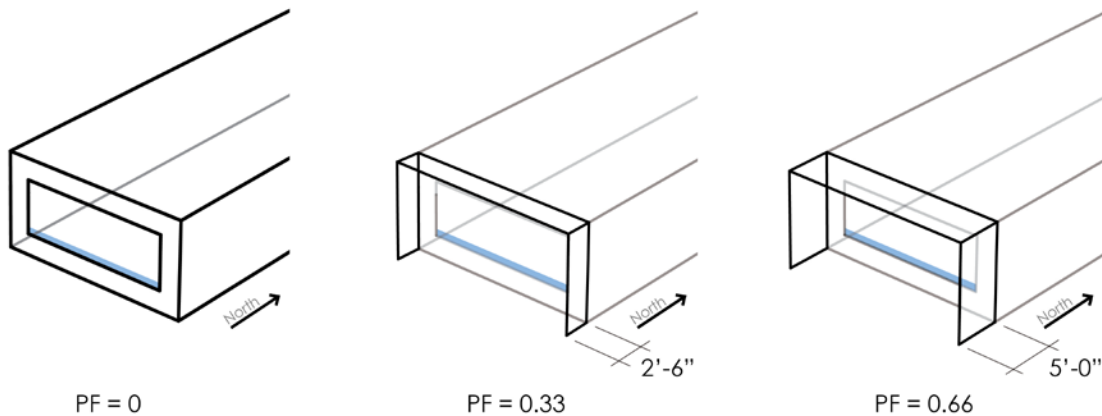

Figure 51. Projection factors tested on the single loaded corridor (SLC) model.

The building envelope of each model was designed with a 40% fenestration ratio as per the IECC 2015. Of the resulting glazing area, three opening areas – 10%, 25%, and 60% – were tested on all models in bulk air flow parametric analysis. The same set of window opening areas were also tested in computation fluid dynamic analysis to visually investigate the effects of window openings on air flow, speed, and comfort. All models were simulated with windows opened year-round and no air conditioning.

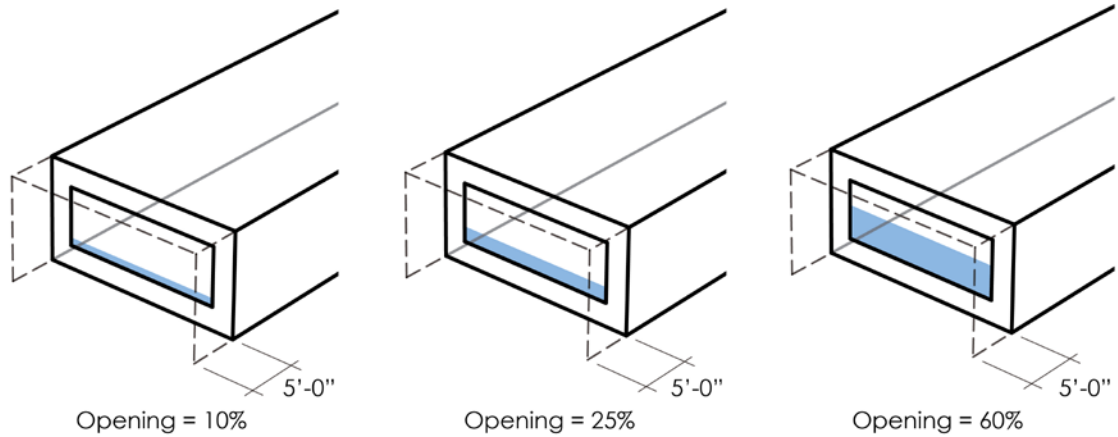

Figure 52. Window opening areas (highlighted) tested on the single loaded corridor (SLC) model.

Local air speeds were modified and tested to demonstrate the effectiveness of ceiling fans on thermal comfort. Ceiling fans can be very beneficial on days with little to no wind as natural ventilation is generally wind-driven. A ceiling fan with a low air speed of 3.3 ft/s has shown a perceived cooling effect of 5.4°F.¹¹⁴ Air speeds tested in each model were increments of 0.5 ft/s. The baseline air speed was 0.33 ft/s, which is considered calm, and maximum being 3.28 ft/s due to the limitation of the simulation software. Air speeds beyond 2.5 ft/s is generally considered uncomfortable not in terms of thermal but a nuisance as at this point paper begins to flutter off tables and hair begins to move. The air speed threshold used for this parametric analysis was 2.5ft/s.

¹¹⁴ (Aynsley 2007)



Figure 53. Increased local air speed relative to perceived comfort. Air speeds of 2.5 ft/s is generally when hair begins to move and paper begins to flutter off tables and thus was chosen as the wind speed threshold. Speeds exceeding this threshold would be considered uncomfortable not in terms of thermal but a nuisance.

Source: *Mechanical and Electrical Equipment for Buildings*

CHAPTER 9

Sets of Analysis

This chapter describes what is being investigated and why.

9.1 Investigate the Effect of Spatial Configuration on Thermal Comfort

Spatial geometry/configuration is important in the tropics as it has an effect on its efficiency to passively ventilate and receive solar radiation. The intent of the analysis of the three models is to demonstrate how effective spatial geometry and configuration is on natural ventilation and thermal comfort. Bulk air flow modeling provides numerical outputs – percent of annual hours of thermal discomfort – of each spatial configuration. The intent of the parametric analyses that follows was to reduce the percent of annual hours of thermal discomfort by manipulating shading projection factors, window opening areas, and local air speeds.

9.2 Investigate the Effect of Building Envelope Design on Thermal Comfort

One of the main design characteristics of tropical vernacular architecture is the building envelope's ability to adapt to the local climate and environmental conditions. Because outdoor conditions in tropical climates are close to the desired indoor conditions the building envelope begins as an open frame structure where the skin is designed to be flexible as to control the incoming environmental forces like sun and wind.¹¹⁵ The building envelope can be modified as to control ventilation for passive cooling and removal of internal heat gain. Most importantly, adequate shading is provided around the building's exterior to prevent penetration from direct sun light thereby minimizing heat gain as much as possible.

Orientation also plays a role in harnessing prevailing winds and receiving solar radiation. Each model was oriented properly with façade openings such as windows facing north/south. The resulting orientation minimized potential heat gain from low east/west sun angles occurring early mornings and late afternoons. The intent of the building envelope parametric analysis was to demonstrate the effectiveness of shading and window opening areas on thermal comfort in the naturally ventilated configuration models.

¹¹⁵ (Grondzik, et al. 2010)



Figure 54. Adaptive behavior on thermal comfort using the elements of the built environment – shading devices and operable windows.

Source: Mechanical and Electrical Equipment for Buildings

9.3 Investigate the Effect of Ceiling Fans on Thermal Comfort

An interior ceiling fan with a low air speed of 3.3 ft/s has shown a perceived cooling effect of about 5.4°F.¹¹⁶ Increased air flow across the skin can help with the evaporation of sweat thereby removing heat from the body quickly and efficiently. Spatial geometry and building envelope, if designed correctly, can be effective in allowing air to flow efficiently throughout the space but sometimes that is not enough, especially on days lacking wind. In a hot and humid climate these conditions can be brutal which is why the use of ceiling fans can be so beneficial. Increasing air speeds via ceiling fans can expand the thermal comfort zone during these conditions as illustrated in figure 55. The intent of the ceiling fan parametric analysis was to demonstrate the effectiveness of increased local air speeds via ceiling fans on thermal comfort.

¹¹⁶ (Aynsley 2007)



Figure 55. Thermal comfort zone expanded with introduction to increased local air speed on the psychrometric chart.

Source: *Mechanical and Electrical Equipment for Buildings*

9.4 Visual Investigation of Air Flow and Speeds in Models (CFD)

Computation fluid dynamic (CFD) modeling was conducted on each model as to further investigate the air flow patterns associated with each spatial configuration. Further investigation was done testing the effects of various window openings on air flow. Visual understanding of how air flows through each model relative to spatial configuration and window opening area provides another perspective on the factors

that play a role in natural ventilation and thermal comfort. CFD modeling also provides a look at high air speeds that would cause a nuisance, a factor that bulk air flow modeling does not recognize when using the PMV model to measure acceptable thermal comfort.

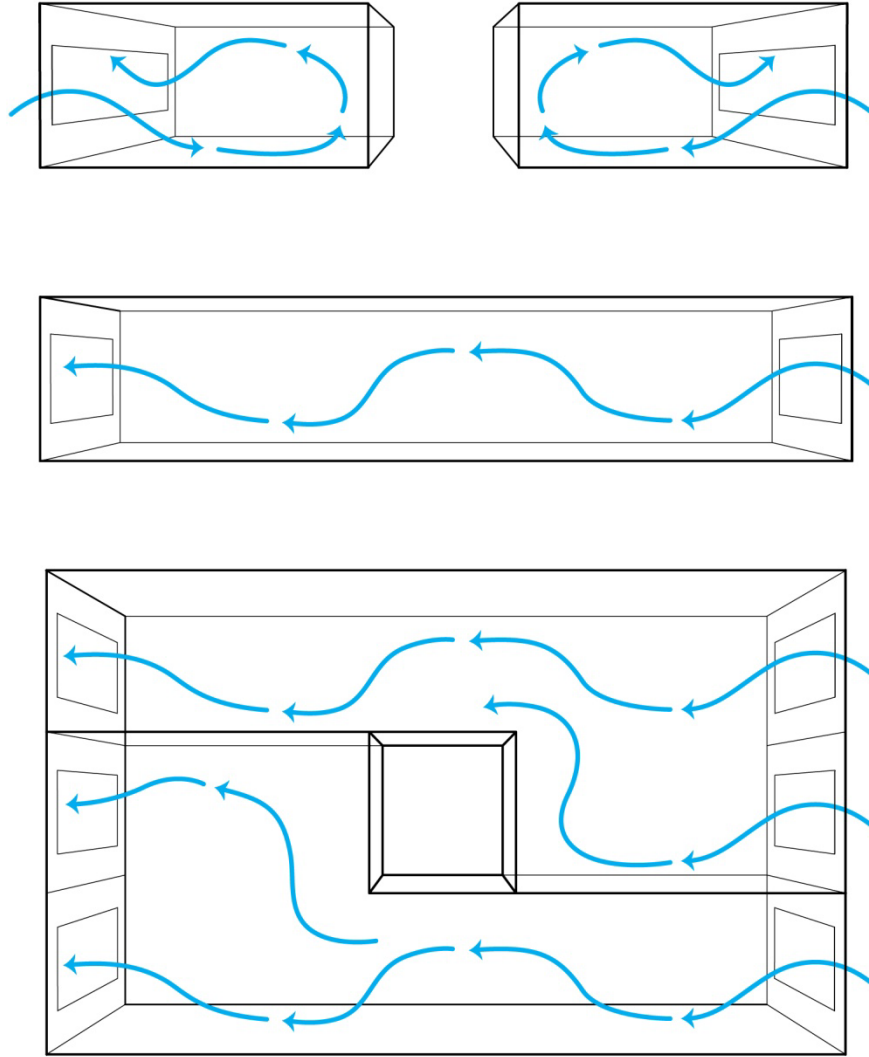

Figure 56. Predicted air flow in each tested spatial configuration model.

CHAPTER 10

Results Breakdown

The results are broken down into two sections; (1) bulk air flow and (2) computational fluid dynamics. The intent of this chapter is to present the results obtained from the analyses. A snapshot of the simulation models and inputs can be found in figure 57 and 58. An overall summary of the results including major key findings and recommendations can be found in Part III.

DLC Double Loaded Corridor

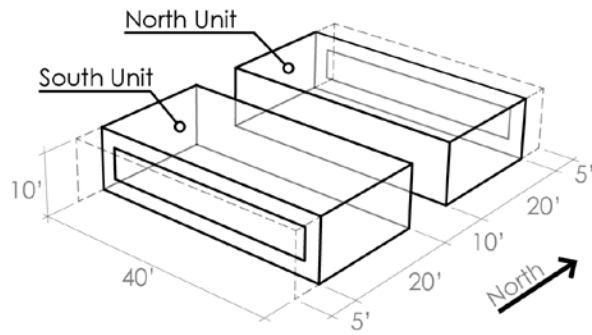

SLC Single Loaded Corridor

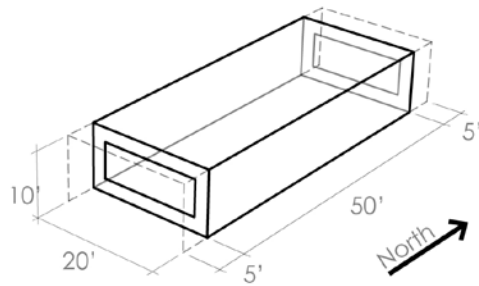

SSDLC Skip-Stop DLC

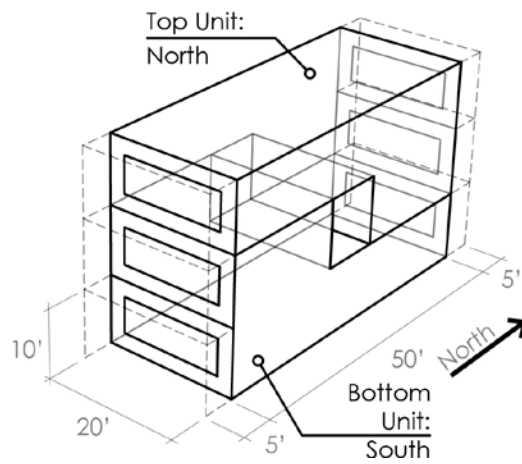

Figure 57. A snapshot of the spatial configuration models tested.

Building Envelope, Construction Materials

Solid Wall Assembly	R-13, steel framing @ 16 in. OC w/ insulation
Internal Partition Assembly	steel framing @ 16 in. OC with insulation
Internal Ceiling/Floor Assembly	4 in. light weight concrete floor deck
Glazing SHGC	0.40
Glazing U-Value	0.95, single-glazed
Glazing (Fenestration) Ratio	40% (10%, 25%, 60% opening areas)
External Shading P.F.	0, 0.33, 0.66

Comfort Parameters

Air Temp (F)	
Men Radiant Temp (F)	Honolulu International Airport
Humidity (%)	TMY3 Weather Data File
Air Velocity (ft/s)	
Clothing Insulation (clo)	0.5 - "casual summer clothing"
Metabolic Rate (met)	58.2 - seated at rest

Internal Heat Loads

Occupancy (people)	2 (400 sqft/person)
Equipment	0
Lighting	1 W/sqft

Figure 58. A snapshot of model inputs for all three spatial configurations. Majority of the inputs were fixed for the exception of shading projection factors, window opening areas, and local air speeds via ceiling fan conducted through a series of parametric analyses.

10.1 Bulk Air Flow

There is not a tremendous amount of knowledge about how the Fanger PMV scale relates to naturally ventilated spaces therefore the comfort zone/threshold used for this investigate in determining acceptable thermal comfort was estimated. The metric used in the bulk air flow analysis was Predicted Mean Vote (PMV) with an upper threshold of +1.5. The total number of hours within a year above the thermal comfort threshold is represented as a percentage. A high percentage indicates thermal discomfort. Hourly conditions below PMV -1.5 rarely occurred due to Honolulu's climate and were not considered as thermally uncomfortable. Discomfort in this case was

assumed to be on the warmer side of the thermal sensation scale based on the Honolulu International Airport weather data file used. Estimated thermal comfort results of each model were not seen as absolute but relative to the three spatial configurations tested in the analyses.

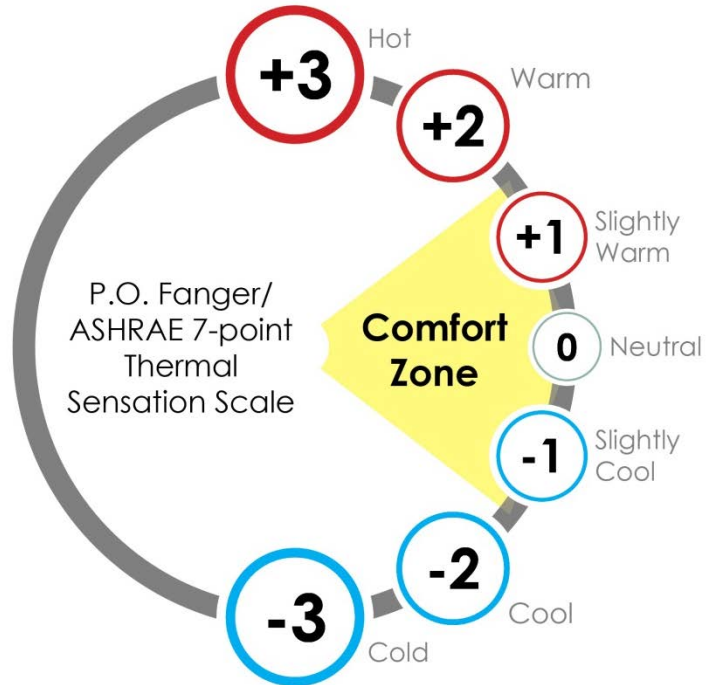

Figure 59. Estimated predicted mean vote (PMV) thermal comfort zone ($-1.5 < \text{Comfort} < +1.5$) used for the analysis in determining acceptable thermal comfort in naturally ventilated configuration models.

Bulk air flow results are broken down into four parts; baseline results showcasing the effect of spatial geometry on thermal comfort (10.1.1), parametric results which include modifications to various shading projection factors (10.1.2), window opening areas (10.1.3), and local air speeds via ceiling fan (10.1.4). A separate analysis was also done investigating the effects of the SSDLC model in two orientations on thermal comfort relative to high and low pressure façades (10.1.5). Each model had all windows opened year-round and no air conditioning. All results represent south facing units of each model unless noted. All results can be found in Appendix A and B.

10.1.1 Spatial Configuration on Thermal Comfort

All three models were assigned a projection factor of 0 (shade-less), 10% window opening area, and 0.33 ft/s internal air speed (considered calm). These variables were later modified to improve thermal comfort in all models. The results acted as a baseline for the parametric analyses that follows.

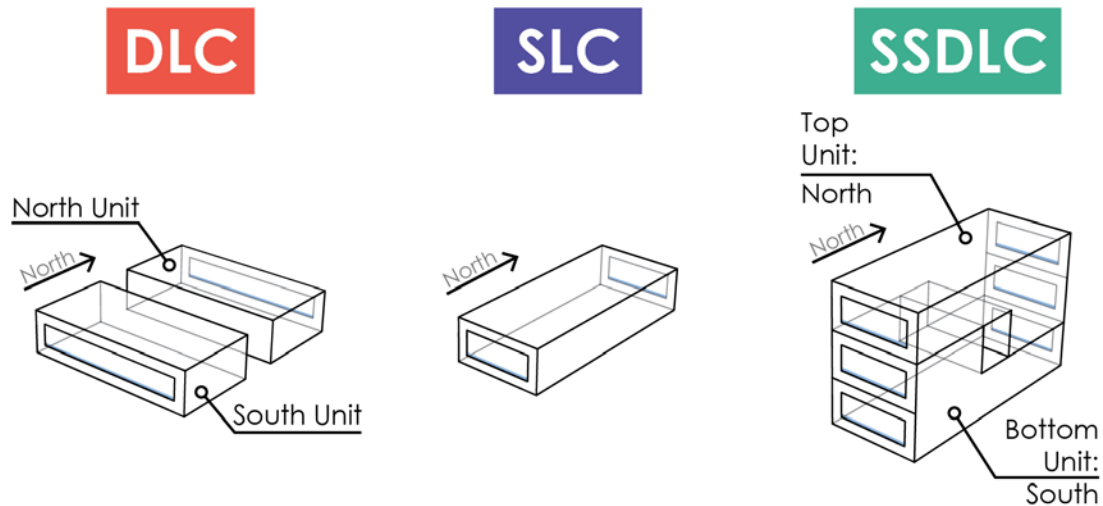

Figure 60. Models tested for the baseline analysis. Each model was assigned with a projection factor (PF) of 0, 10% window opening area, and 0.33ft/s local air speed (calm).

The effectiveness of spatial configuration on thermal comfort is seen in figure 61. With the PMV upper threshold of +1.5, the double loaded corridor (DLC) experienced thermal discomfort about 58% of the year making it the least comfortable relative to the other configurations. One could assume, in this case, that 58% of the year would require air conditioning to offset thermal discomfort that is associated with this particular spatial configuration. Therefore, we can also assume the other two models – single loaded corridor (SLC) and skip-stop double loaded corridor (SSDLC) – not only showed reduction in annual thermal discomfort but reduction in energy consumption as these configurations were able to provide enhanced thermal comfort using natural ventilation more so than the DLC model lessening the need for air conditioning as a result.

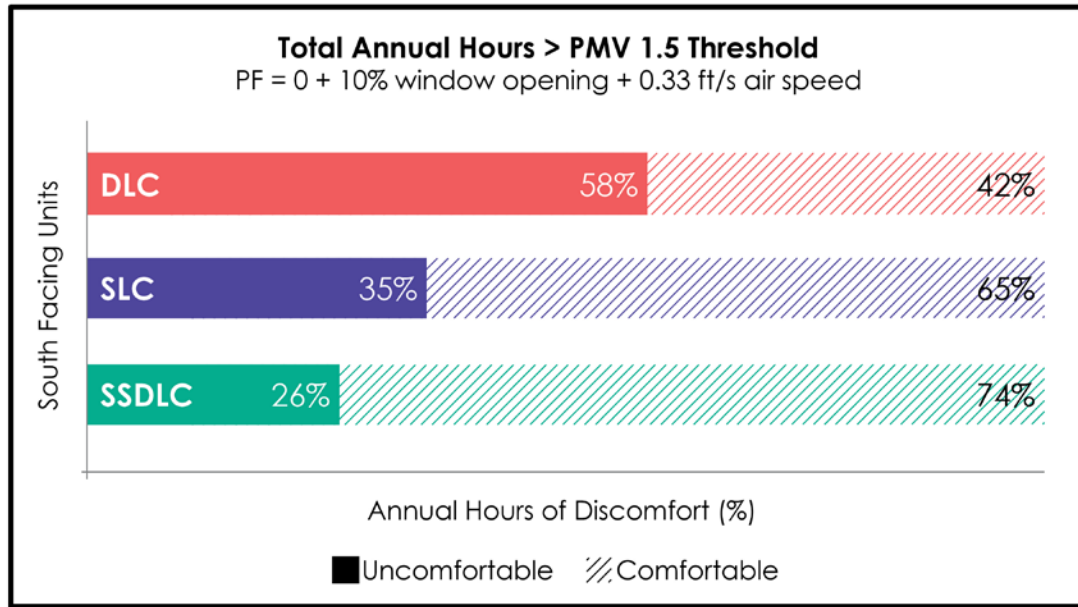

Figure 61. Total annual hours above the predicted mean vote (PMV) upper threshold of +1.5 for all models, specifically south facing units with windows opened year-round and no air conditioning.

Figure 62 breaks down the results seen in figure 61 illustrating the annual hours of thermal sensations experienced within each model. The thermal sensations are relative to PMV values; 3.0=hot, 2.0=warm, 1.0=slightly warm, 0=neutral, -1.0=slightly cool, -2.0=cool, -3.0=cold. The results demonstrate that in all cases the thermal sensations experienced within each spatial configuration were on the warmer side of the PMV thermal sensation scale as expected. However, thermal sensations in each model were not entirely on the warmer side of the thermal sensation scale. A good percentage of the year, especially in the SSDLC model, dipped below PMV 0 (thermally neutral) and into the cooler side of the scale. The objective of the parametric analyses that follows was to reduce the total number of hours within a year above the thermal comfort threshold of PMV +1.5 by modifying shading projection factors, window opening areas, and local air speeds via ceiling fans.

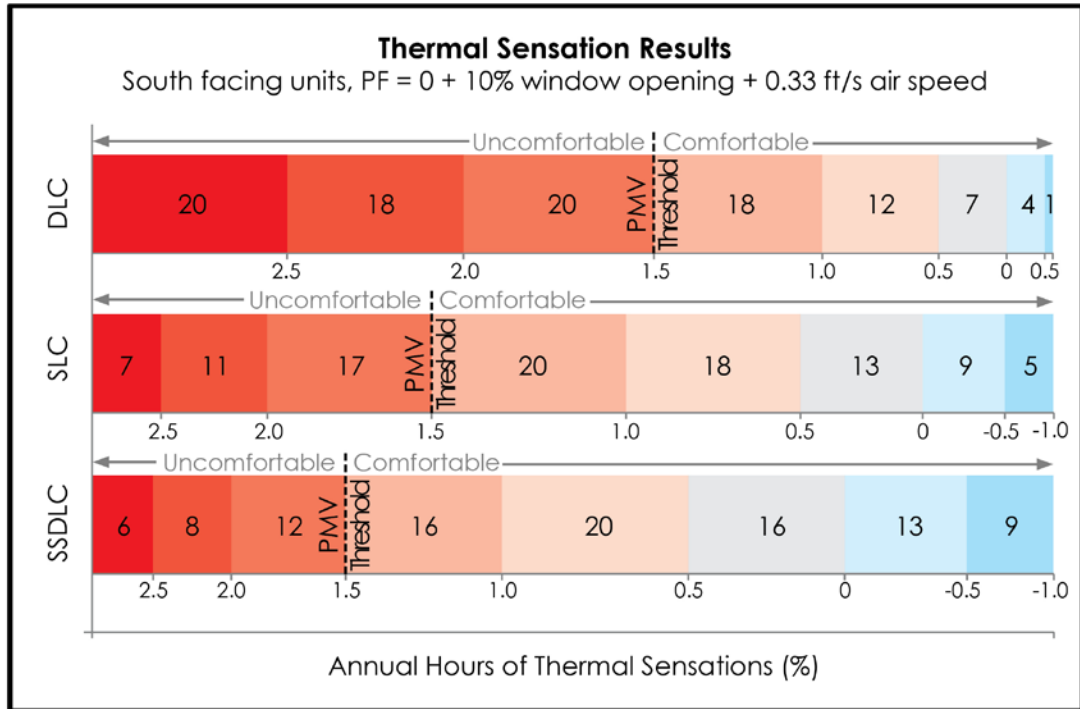

Figure 62. Thermal sensation results of each spatial configuration, specifically south facing units. Number of annual hours to the left of the PMV threshold was considered uncomfortable. Numbers of annual hours are relative to thermal sensations experienced in each model and are presented in sets. The SSDLC model experienced cooler thermal sensations (annual hours below PMV 0, neutral) 22% of the year relative to the other models.

10.1.2 Shading Projection Factor

The objective of this parametric analysis was to reduce the number of hours within a year above the thermal comfort threshold of PMV +1.5 by introducing box shading devices with various projection factors. Three projection factors were tested on all models – 0 (shade-less), 0.33, and 0.66 – as to measure the effects of shading on thermal comfort. The projection factor (PF) is based on the ratio of the overhang depth to the overhang height above the window sill. A projection factor of 0.33 equated to a 2'-6" overhang and 0.66 equated to a 5'-0" overhang based on the building envelope design of each model. Figure 63 provides illustrations of each tested model assigned these projection factors for the parametric analysis. Models with a 10% window opening area and 0.33 ft/s local air speed (calm) were used as a baseline for this analysis.

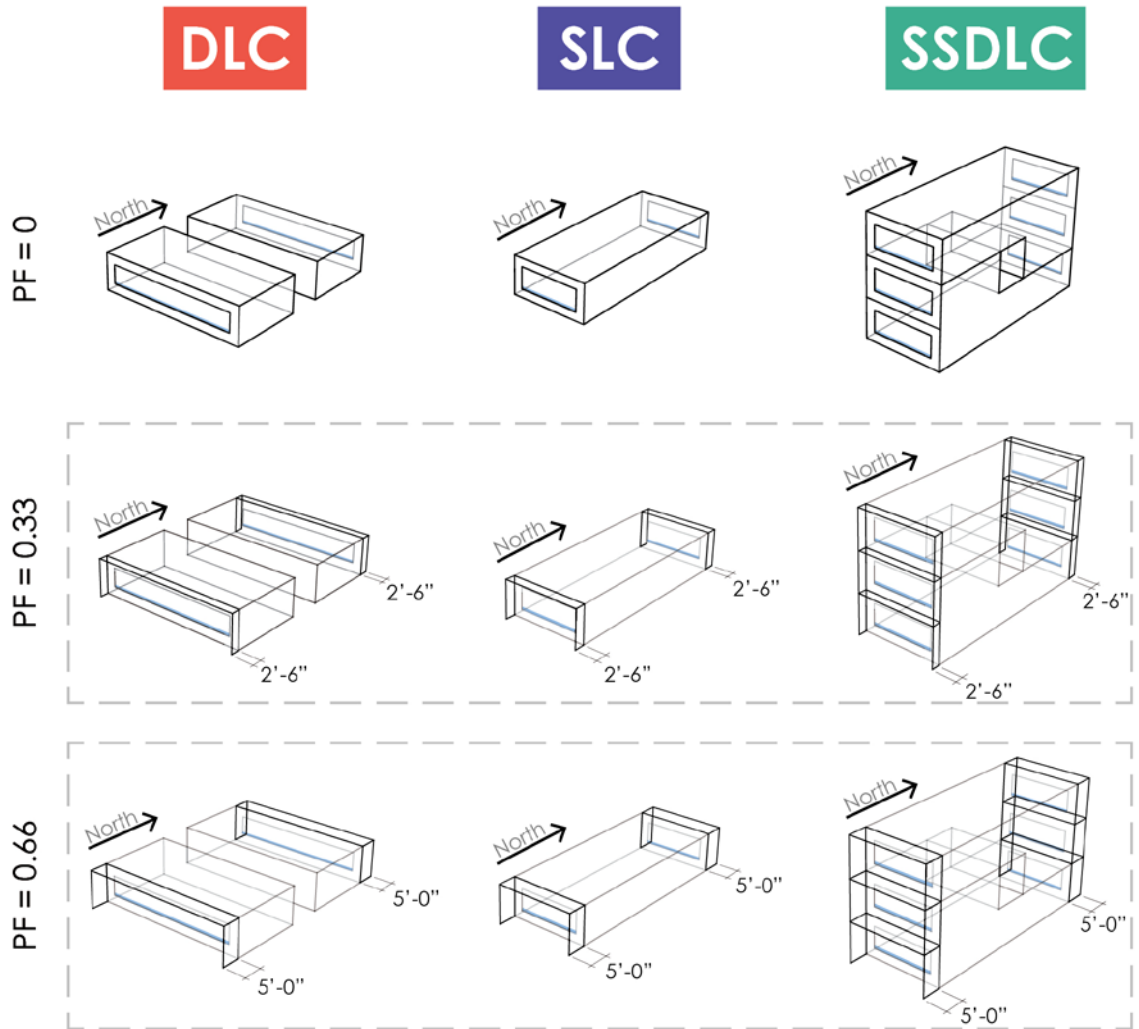

Figure 63. Models tested for the shading projection factor (PF) parametric analysis. All models were assigned a 10% window opening area and 0.33 ft/s local air speed (calm).

The importance of shading devices is clear; however, not as significant for north and south orientations only. The orientation of each unit minimized potential heat gain from low east/west sun angles occurring early mornings and late afternoons. Thermal comfort improvements were also not as significant due to the center locations of each unit relative to the building mass it resided in. Units that were located on the east and west facing sides of the building were not simulated in this analysis. Units located on the top level of the building were also not considered due to higher solar radiation.

Installing a shading device with a PF of 0.33, equivalent to 2'-6" overhang depth, decreased thermal discomfort by 1-2% in all cases. A shading device with a PF of 0.66,

equivalent to 5'-0" overhang depth, reduced thermal discomfort by at least 4-6% in all cases. The DLC model was the least comfortable of the three. The SSDLC model showed the biggest improvement when using a 0.66 projection factor, a 6% decrease in thermal discomfort throughout the year.

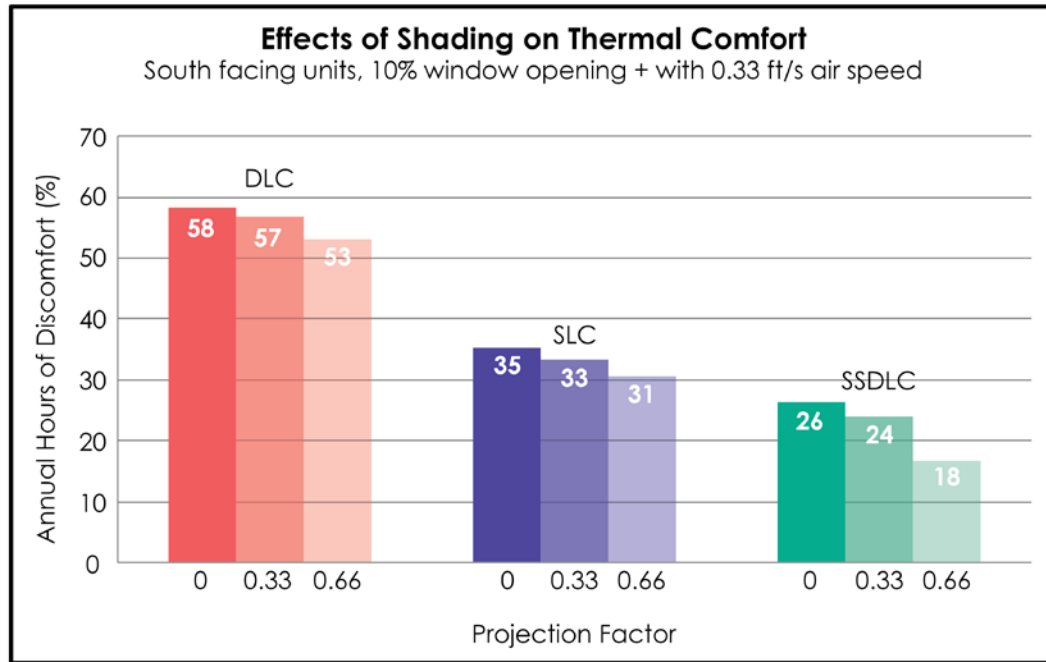

Figure 64. Effects of shading on thermal comfort.

South facing units resulted in a higher percent of thermal discomfort than north facing units with or without shading devices in all cases. South facing units, due to the location of this analysis, experienced higher solar radiation and therefore resulted in higher thermal discomfort than north facing units, specifically in regards to the DLC model. The SLC model is a special case since it did not have a north or south unit. The SSDLC configuration did have a north and south facing unit but demonstrated slightly different results as seen in figure 65.

The annual hours of thermal discomfort with projection factors of 0 and 0.33 were similar for both north and south facing units in the SSDLC model. The south facing unit performed slightly better than north facing unit with a shading projection factor of 0.66. This suggests that projection factor alone was not only the cause of this result but spatial configuration relative to air flow. This was further investigated in section 10.1.5 where an

analysis was done purely on SSDLC model orientations relative to high/low pressured façade. CFD modeling was also done to visually examine air flow and speeds of each unit in two different orientations that could have resulted in the south unit performing better than the north despite having higher solar radiation.

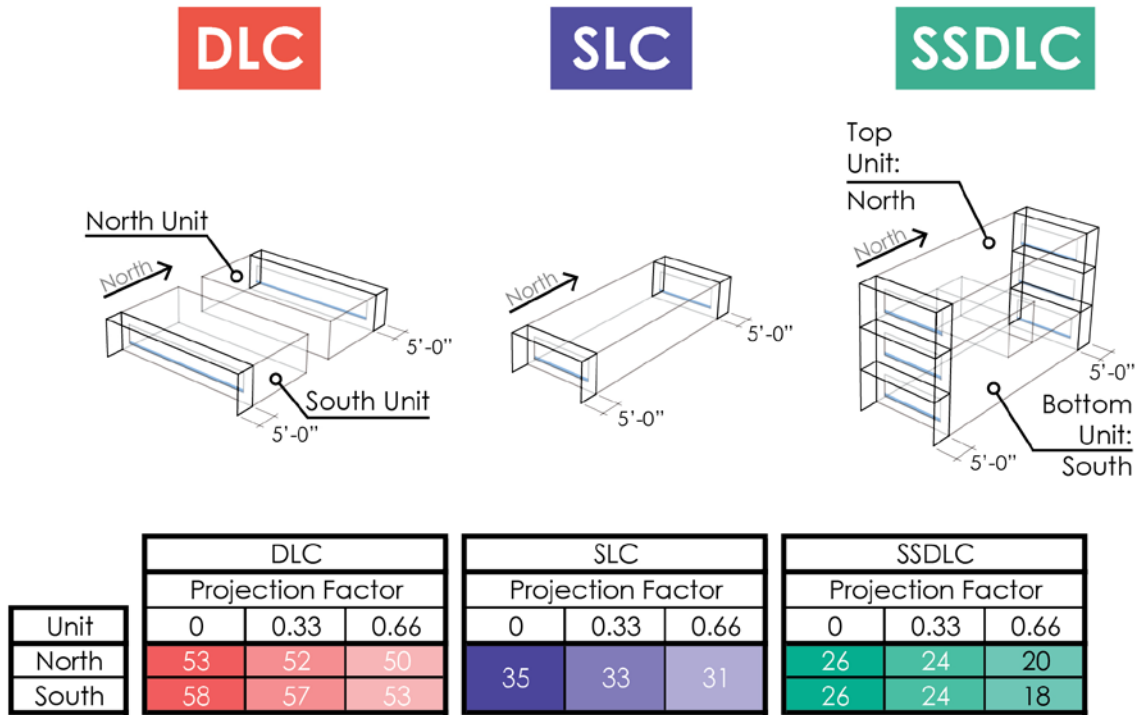

Figure 65. Effects of shading on thermal comfort, comparison of north and south facing units in all spatial configurations. Numbers in the colored boxes are percentages representing annual hours of thermal discomfort (PMV>+1.5). The south unit of the SSDLC model performed slightly better than the north when assigned a shading projection factor of 0.66 relative to units of the DLC model with similar shading conditions.

10.1.3 Window Opening Areas

The objective of this parametric analysis was to further reduce the number of hours within a year above the thermal comfort threshold of PMV +1.5 by manipulating window opening areas. The intent of this analysis was to also demonstrate the effectiveness of window openings on natural ventilation and thermal comfort. Models with a projection factor of 0.66 or 5'-0" overhang were used as a baseline for this analysis. The building envelope of each model was designed with a 40% fenestration

ratio. Of the resulting glazing area, which was assigned as a louvered-type window, three opening areas were tested on all models – 10%, 25%, and 60%. Figure 66 provides illustrations of each model tested for this parametric analysis with their corresponding window opening area highlighted in blue.

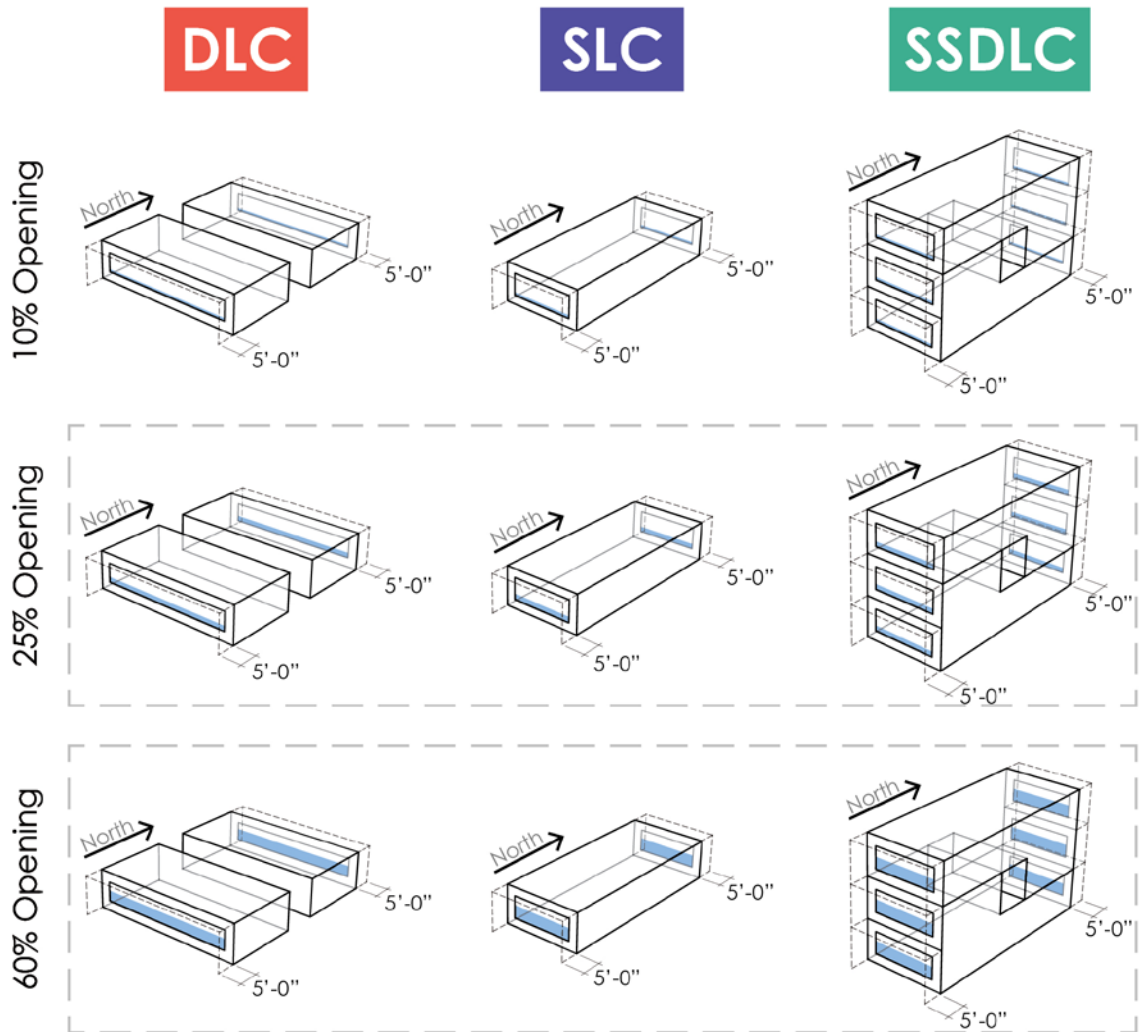

Figure 66. Models tested for window opening area parametric analysis. Each model was assigned a projection factor of 0.66 (5'-0" overhang) and local air speeds of 0.33 ft/s (calm).

The effects of window openings on natural ventilation and thermal comfort are clearly demonstrated in figure 67. Although the double loaded corridor was the least comfortable of the three models it showed the greatest reduction in thermal discomfort when assigned a 25% and 60% window opening area. Assigning a 60% window opening

area to the DLC model reduced annual thermal discomfort by 32%. Greater window opening area resulted in better air exchange thus improving air flow and thermal comfort within each DLC unit.

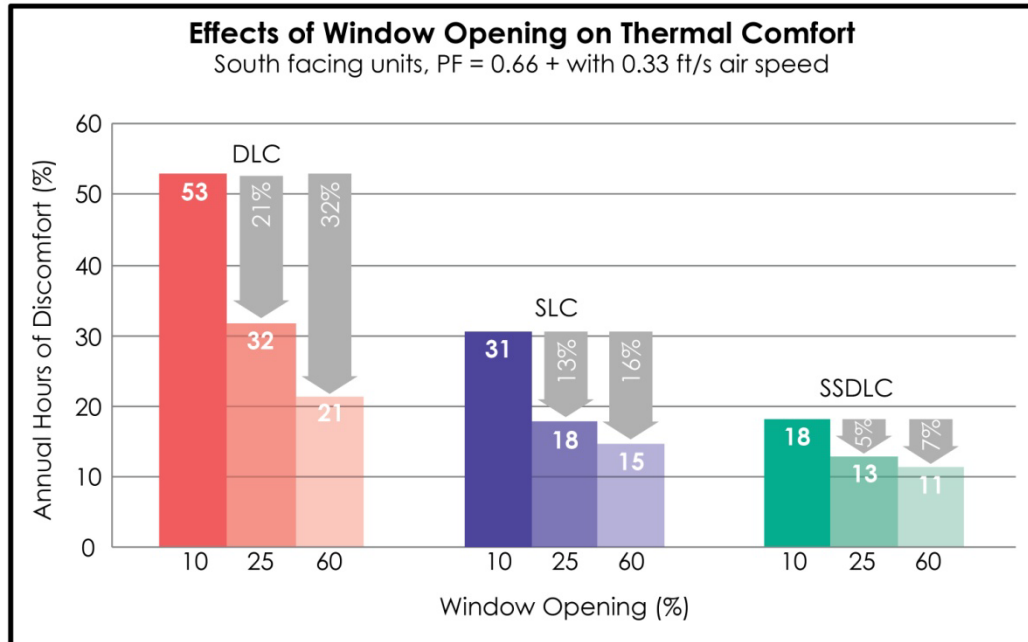

Figure 67. Effects of window opening area on thermal comfort.

The SSDLC model showed the least reduction in thermal discomfort when assigned various window opening areas but still outperformed the others resulting in thermal discomfort 11% of the year when assigned 60% window opening area. Greater amount of building façade openings was likely the reason the SSDLC model performed best as this would have significantly increased air flow and speeds in the space resulting in improved thermal comfort. This was further investigated with CFD modeling. It is not made clear in the bulk air flow results what the air speeds are in each model relative to window opening areas that were tested. Bulk air flow modeling is limited in some ways in that it does not recognize high air speeds as a nuisance. CFD modeling was also utilized to visually investigate air speeds in each model relative to window opening areas to determine whether or not these speeds were a nuisance.

10.1.4 Local Air Speeds

The objective of this parametric analysis was to further reduce the number of hours within a year above the thermal comfort threshold of PMV +1.5 by increasing local air speeds produced by a low speed high volume ceiling fan. The simulations were conducted with incremental increases of local air speeds of 0.5 ft/s demonstrating the effectiveness of ceiling fans on thermal comfort. Many would find that air speeds exceeding 2.5 ft/s to be a nuisance as at this point hair begins to move and paper begin to flutter off tables. Therefore, 2.5 ft/s was the targeted air speed for this analysis as speeds exceeding this would be considered uncomfortable not in terms of thermal but more as a nuisance. Models with a projection factor of 0.66 (5'-0" overhang) and 60% window opening area were used as a baseline for this analysis.

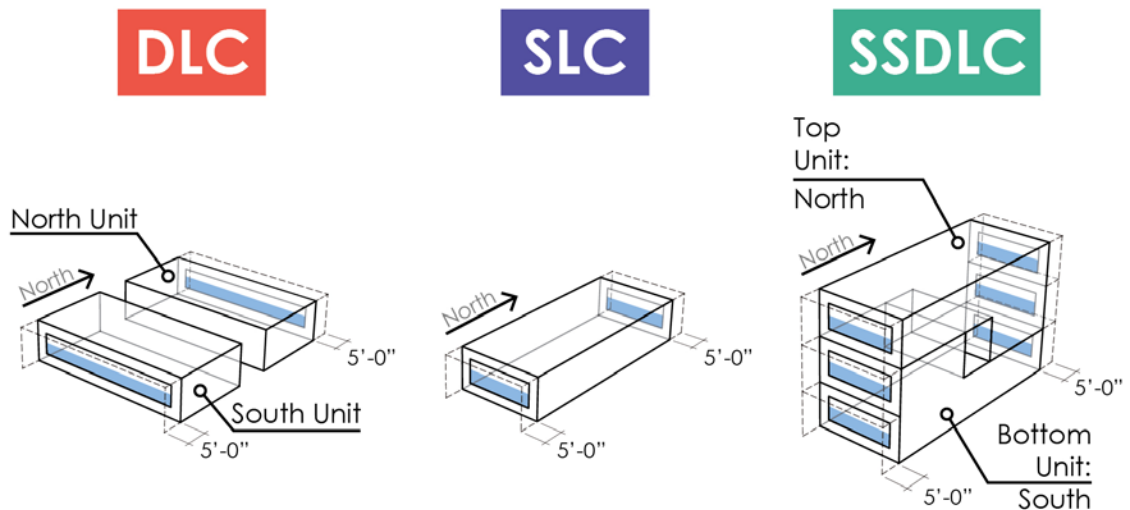

Figure 68. Models tested for local air speed parametric analysis. Each model was assigned a 0.66 projection factor and 60% window opening area.

It is clear that higher local air speeds improve thermal comfort in all cases. The results in figure 69 demonstrated the effectiveness of using low speed, high volume fans on thermal comfort. The DLC model was the least comfortable of the three models but had the greatest reduction in thermal discomfort when higher air speeds were applied. The DLC model experienced an 8% reduction when assigned a local air speed of 2.33 ft/s while the SLC model showed a 6% reduction and SSDLC showed 5% reduction with the same air speed. The point of diminishing returns occurs at this point where air speeds exceeding 2.33 ft/s start to become less effective in improving thermal comfort.

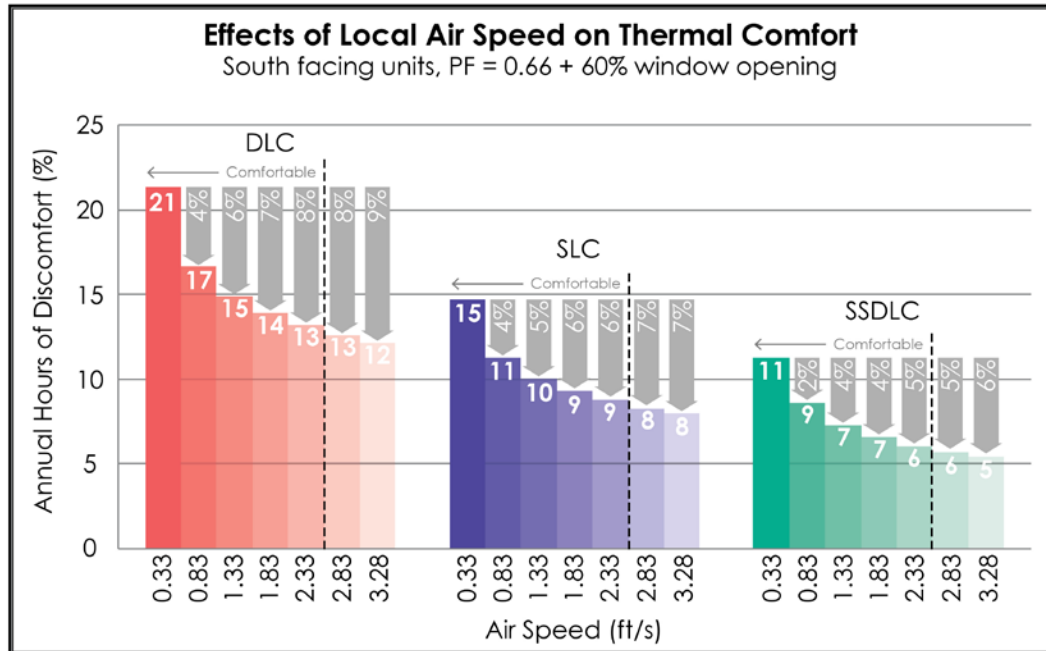

Figure 69. Effects of local air speed on thermal comfort.

10.1.5 Skip-Stop Double Loaded Corridor Orientations

Due to the SSDLC unique spatial configuration a comparative analysis was done with the model placed in two different orientations. The intent of this analysis was to better understand the effects of the double height ceiling location or façade with greater openings relative to high versus low pressure façades. Two orientations were tested – (1) original 0-degree orientation and (2) 180-degree orientation. Figure 70 provides a visual representation of how these two models and their building envelopes were oriented relative to high/low pressure facades during the simulations.

The high pressure or windward façade was oriented north as Honolulu’s prevailing winds comes from north-east direction while low pressure or leeward façade was oriented south, according to the Honolulu International Airport TMY3 weather data file. Note that the name of each unit used in this analysis was relative to the location of the façade with greater openings (double height ceiling space) whether it was the top or bottom unit within the model. Each model was assigned a projection factor of 0.66 (5’-0” overhang), 60% window opening area, and 0.33 ft/s local air speed.

SSDLC

Skip-Stop DLC (0°)

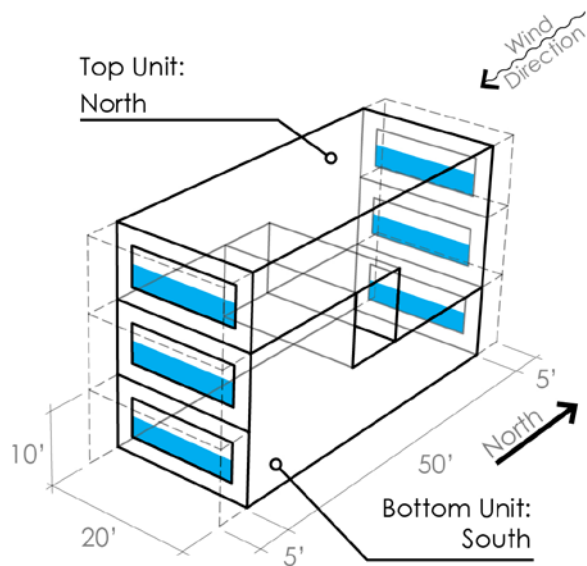

SSDLC

Skip-Stop DLC (180°)

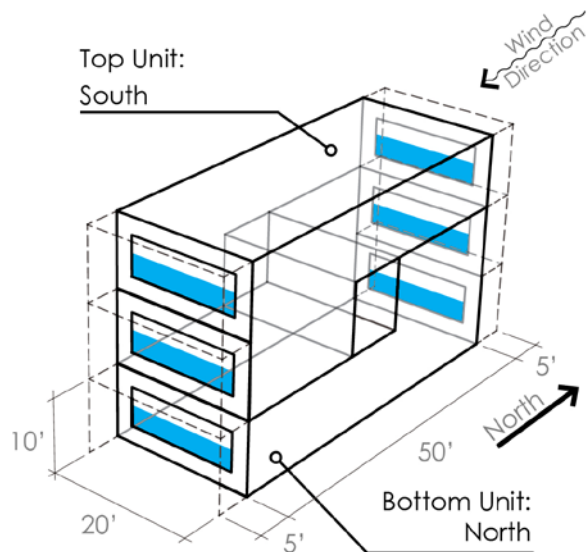

Figure 70. SSDLC models tested for the orientation analysis. Each model was assigned a 0.66 projection factor, 60% window opening area, and 0.33 ft/s local air speed.

The results demonstrate that the unit with the façade with fewer openings oriented toward the high pressure facade had a 2% reduction in annual hours of thermal discomfort compared to the other unit in the opposite orientation. Figure 71 compare the results of the original orientation with the new 180-degree orientation. It clearly indicates that having facades with greater openings oriented toward the low pressure façade and facades with fewer openings oriented toward the high pressure facade resulted in fewer annual hours of thermal discomfort in all cases.

The thought is that “cross ventilation is optimum well when inlet openings are slightly smaller in total area than outlet openings” as suggested by DBEDT and other sources.¹¹⁷ This is certainly the case with larger opening area produced by the double height ceiling oriented toward the low pressure façade and smaller opening area oriented toward the high pressure façade. When the model was in its original orientation the bottom unit performed better than the top due to the location of the window inlets and outlets relative to high and low pressure façade. The top unit performed better when the model was oriented 180 degrees.

¹¹⁷ (DBEDT 2002)

SSDLC Skip-Stop DLC (0°)

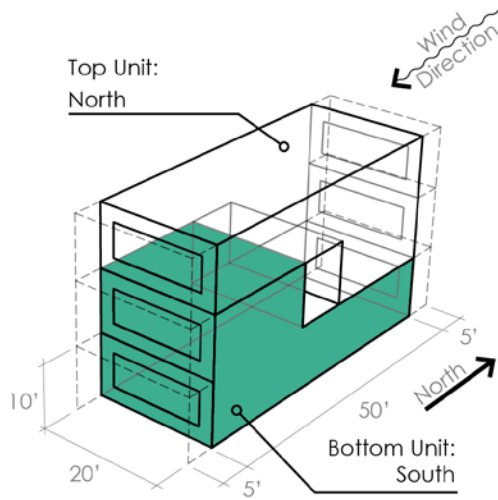

SSDLC Skip-Stop DLC (180°)

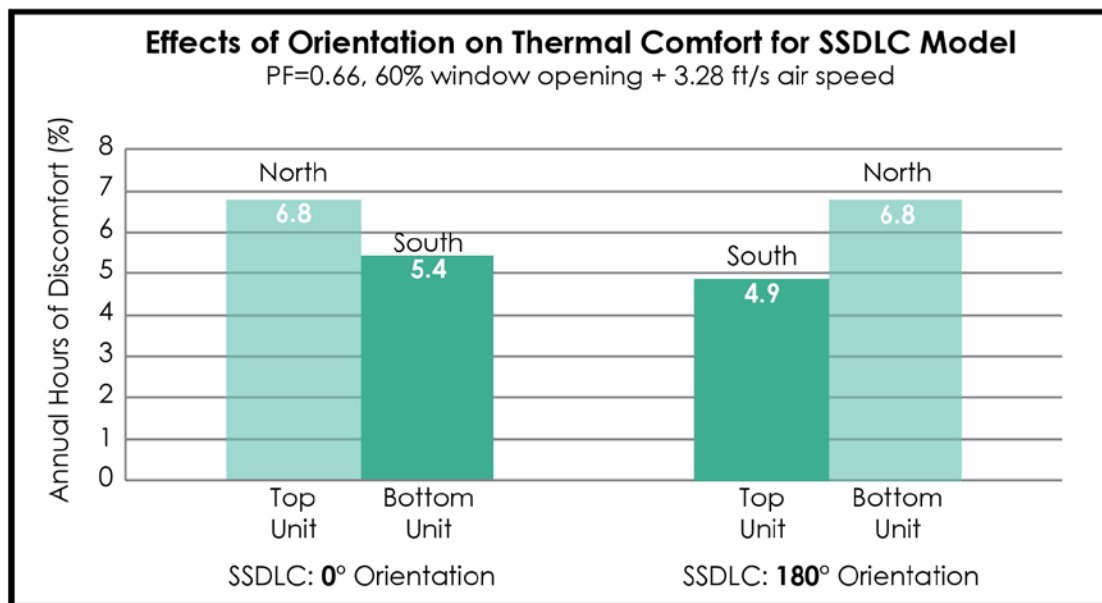
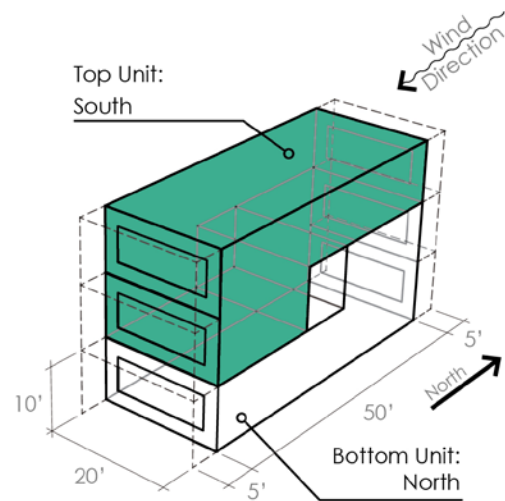

Figure 71. Skip-top double loaded corridor orientation results. The highlighted unit in each model performed 2% better than the opposite unit due to its inlet and outlet locations relative to high and low pressure façade.

The same window opening area and local air speed parametric analysis was done with the new 180-degree orientation and nearly all results were inverse of the original orientation results as seen in figure 72. The double height ceiling location or

façade with greater openings oriented toward the low pressure façade resulted in fewer annual hours of thermal discomfort in all cases whether it was the top or bottom unit in the spatial configuration. Providing fewer openings on the low pressure facade and greater openings on the high pressure facade resulted in better air flow in the space thus provided better thermal comfort than having opposing conditions. A more detailed analysis of these conditions was further investigated with CFD modeling that follows.

Local Air Speed (ft/s)	Unit	Orientation	SSDLC			Orientation	SSDLC (180°)		
			Window Openings (%)				Window Openings (%)		
			10	25	60		10	25	60
0.33	Top	N	20	14	12	S	18	12	11
	Bottom	S	18	13	11	N	21	14	13
0.83	Top	N	15	11	10	S	13	9	8
	Bottom	S	13	10	9	N	16	11	10
1.33	Top	N	16	9	9	S	11	8	7
	Bottom	S	14	8	7	N	14	9	9
1.83	Top	N	11	9	8	S	10	7	6
	Bottom	S	10	7	7	N	12	9	8
2.33	Top	N	11	8	7	S	9	6	6
	Bottom	S	9	7	6	N	11	8	7
2.83	Top	N	10	8	7	S	8	6	5
	Bottom	S	9	6	6	N	10	8	7
3.28	Top	N	10	8	7	S	8	6	5
	Bottom	S	8	6	5	N	10	8	7

Figure 72. Orientation comparison of the skip-stop double loaded corridor with various window openings relative to local air speeds. Numbers in colored boxes represent the percent of annual hours of thermal discomfort. Projection factors for these models were 0.66 (5'-0") in all cases. Percent of annual hours of thermal discomfort in the 180-degree orientation were inverse of the original orientation results demonstrating the effects of providing fewer openings toward the high pressure façade and greater openings toward the low pressure façade.

10.2 Computational Fluid Dynamics (CFD)

Bulk air flow modeling was limited in some ways in that it did not recognize high air speeds as a nuisance. Therefore, the intent of CFD modeling was to visually investigate the air flow patterns and speeds associated with each spatial configuration relative to window opening areas. CFD modeling, limited to point-in-time (PIT) results, was done using the environmental conditions on a day and time during the hotter season of the year but at the same time breezy enough for wind-driven ventilation – August 26 at 8:00 (20:00) pm – according to the Honolulu International Airport TMY3 weather data file. Wind speeds and directions are unpredictable each day and season throughout the year and so it should be made clear that the PIT results are not representation of what was happening in each spatial configuration year-round but rather a snapshot in time.

Natural ventilation can be induced by cross ventilation (wind-driven) or stack ventilation (buoyancy-driven). CFD analysis looks at purely wind-driven ventilation for both single and double sided ventilation relative to each model being tested. Each model was simulated with three window opening areas – 10%, 25%, and 60% – similarly to what had been done in the bulk air flow analysis. The visual results, a three-dimensional section perspective, demonstrated how air flows through each spatial configuration relative to the assigned window opening areas. Window opening areas of the 40% fenestration area developed for each model is highlighted in all results. The targeted maximum air speed in this analysis was 2.5ft/s. Air speeds exceeding 2.5 ft/s were considered uncomfortable not in terms of thermal but more of a nuisance.

PMV values of each space during the particular moment in time when this analysis was conducted was also provided in the results as to provide a perspective of the thermal sensation associated with the given air flow in the space relative to window opening areas. Each model was assigned a projection factor of 0.66 (5'-0" overhang) and simulated with "semi-exposed" façades to reflect air flow patterns associated with a high rise urban environment. Local air speeds were not manipulated and in this case were relative to the external conditions (wind pattern and speed) on August 26 at 8:00pm. Wind was blowing from north-east at 22 ft/s (15 mph) on that day and time the analysis was taken according to the weather data file. In the presented CFD visual

results north is to the right of each model therefore air flowing into each model is also coming from the right as well simulating a north-east prevailing wind pattern.

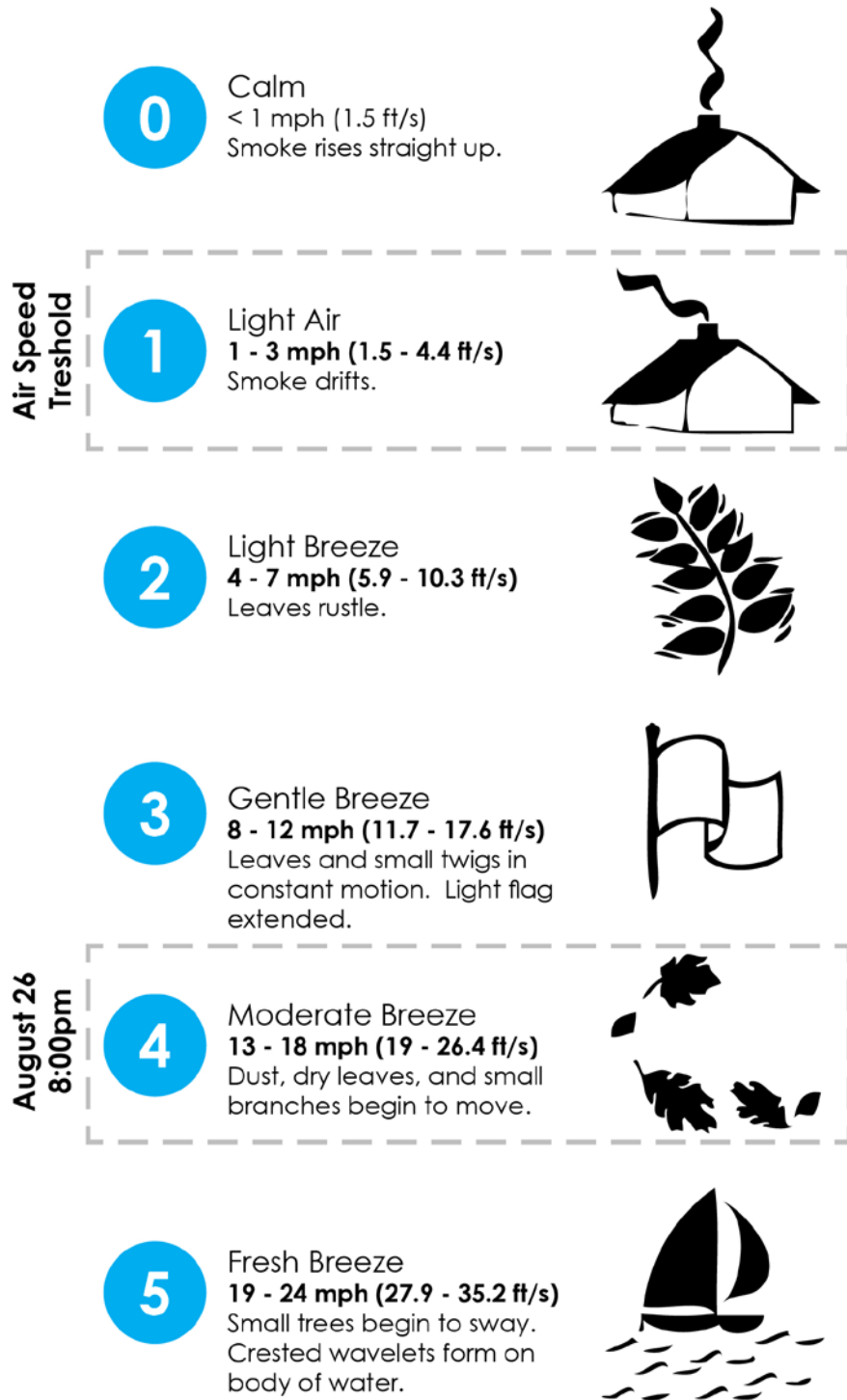

Figure 73. Beaufort scale and effects felt on land. Wind conditions on August 26 at 8:00pm were categorized as Beaufort number 4 exceeding the air speed comfort threshold of 2.5 ft/s.

Source: NOAA, redrawn by author.

10.2.1 Double Loaded Corridor

With a 60% window opening area and an average wind speed of 22 ft/s (15 mph) the internal air speeds experienced in the DLC model remained relatively low but enough to provide some ventilation. It was clear that during this particular point-in-time ceiling fans would be helpful in increasing air speeds within each unit to aid with single-sided ventilation. The PMV values associated with both north and south facing units were identical in all cases. This may have been due to the time of day from which the analysis was taken from – 8:00pm – when there was no sun to produce solar radiation that would otherwise produce an offset of PMV values between the north and south facing unit. Overall, this configuration produced little air speeds due to the access corridor acting as an internal barrier to air flow thus contributing to the high annual percent of thermal discomfort as seen in the bulk air flow results.

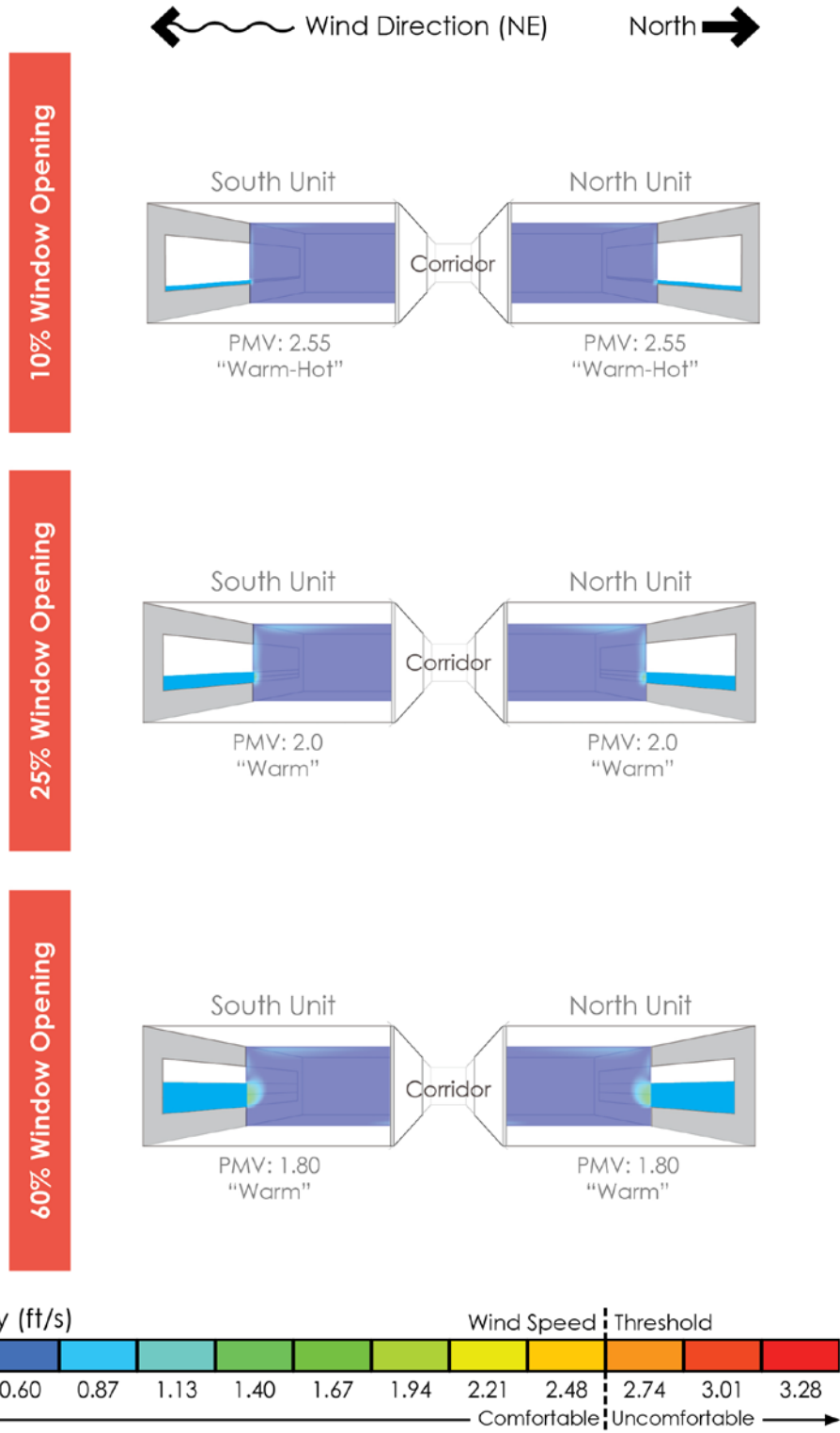

Figure 74. Double loaded corridor CFD results on August 26 at 8:00pm. Single-sided ventilation associated with this spatial configuration resulted in lack of air flow and speeds in all cases.

10.2.2 Single Loaded Corridor

“Cross ventilation in a room is only guaranteed when the room has two (preferably) opposite windows with high pressure difference across them.”¹¹⁸ Double-sided ventilation associated with the single loaded corridor configuration allowed for pressure differences to occur on both the windward and leeward facades thus inducing air flow into the space. Air speeds, seen coming from the north (windward) façade, might be high enough to be a nuisance depending on the proximity to the window opening as seen in figure 75. Providing 60% window opening area resulted in great area of high air speeds that would be considered uncomfortable. Assigning the model with 25% window opening area resulted in just the right amount of air flow and speeds to provide sufficient passive cooling without becoming a nuisance. Lack of air flow and speeds can be seen in the model when assigned a 10% window opening area. Providing operable windows for occupant control would allow manipulation of air flow in the space based on the occupant’s air speed preference.

Although the CFD results visually demonstrate air flow patterns within the model the PMV values indicated below them suggests during this time and day the thermal sensation experienced in the space exceeds the thermal comfort threshold of PMV +1.5 in all cases. Although it is not made clear, higher air temperature and humidity during this time and day could have contributed to higher PMV values and not air speed. The visual results seen in figure 75 demonstrate how effective larger window opening areas are on air flow in a naturally ventilated space and thermal comfort with the incremental reduction of the PMV values.

¹¹⁸ (Gomaa 2013)

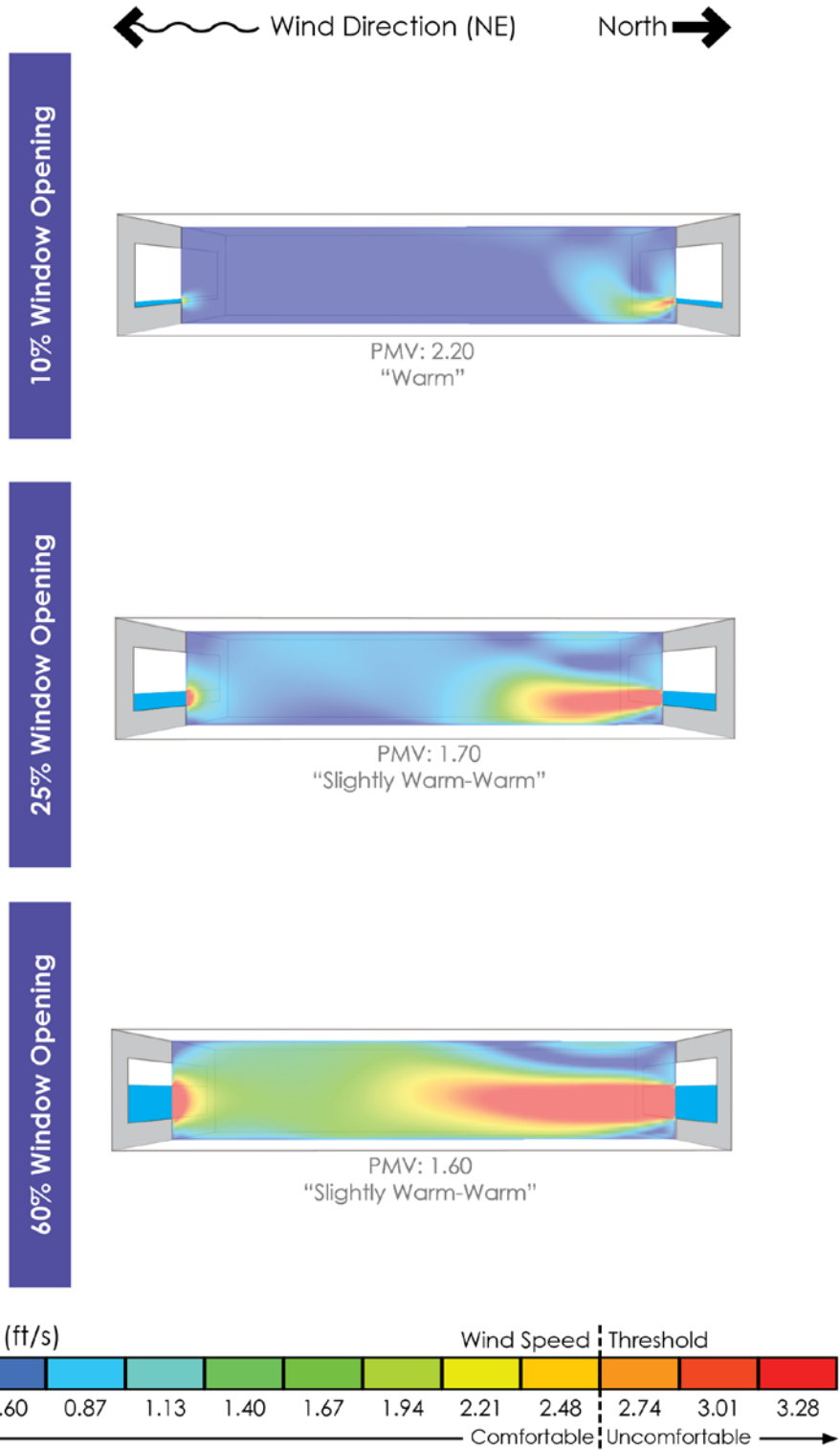

Figure 75. Single loaded corridor CFD results on August 26 at 8:00pm. Providing double-sided ventilation allowed for pressure differences to occur on either façade inducing air flow.

10.2.3 Skip-Stop Double Loaded Corridor (0°)

Similarly, to the SLC model, double-sided ventilation associated with the SSDLC configuration allowed for pressure differences to occur on both the windward and leeward facades thus inducing air flow into the space. The CFD results visually in figure 76 demonstrate air flow patterns within the skip-stop double loaded corridor spatial configuration model relative to window opening area. Larger window openings provided better air flow within the space. However, similarly to the SLC model, providing 60% window opening area produced a greater area of air speeds that exceed the comfort threshold and were considered uncomfortable despite having lower PMV values relative to the other models.

Thermal sensations experienced in this spatial configuration during this time and day suggests the bottom unit, having fewer openings toward the high pressure or windward facade produced a PMV of 0.05 lower than the top unit. Although this difference was minute, the thermal sensations in PMV are consistent with bulk air flow modeling results. Fewer openings on the high pressure facade and greater openings on the low pressure facade produced a lower percentage of annual hours of thermal discomfort the adjacent unit with opposite conditions. However, despite lower PMV, the visual results of the bottom unit show air speeds that might be high enough to be a nuisance depending on the proximity to the window opening as seen in figure 76. Further investigation was done on the SSDLC with the model orientated 180 degrees.

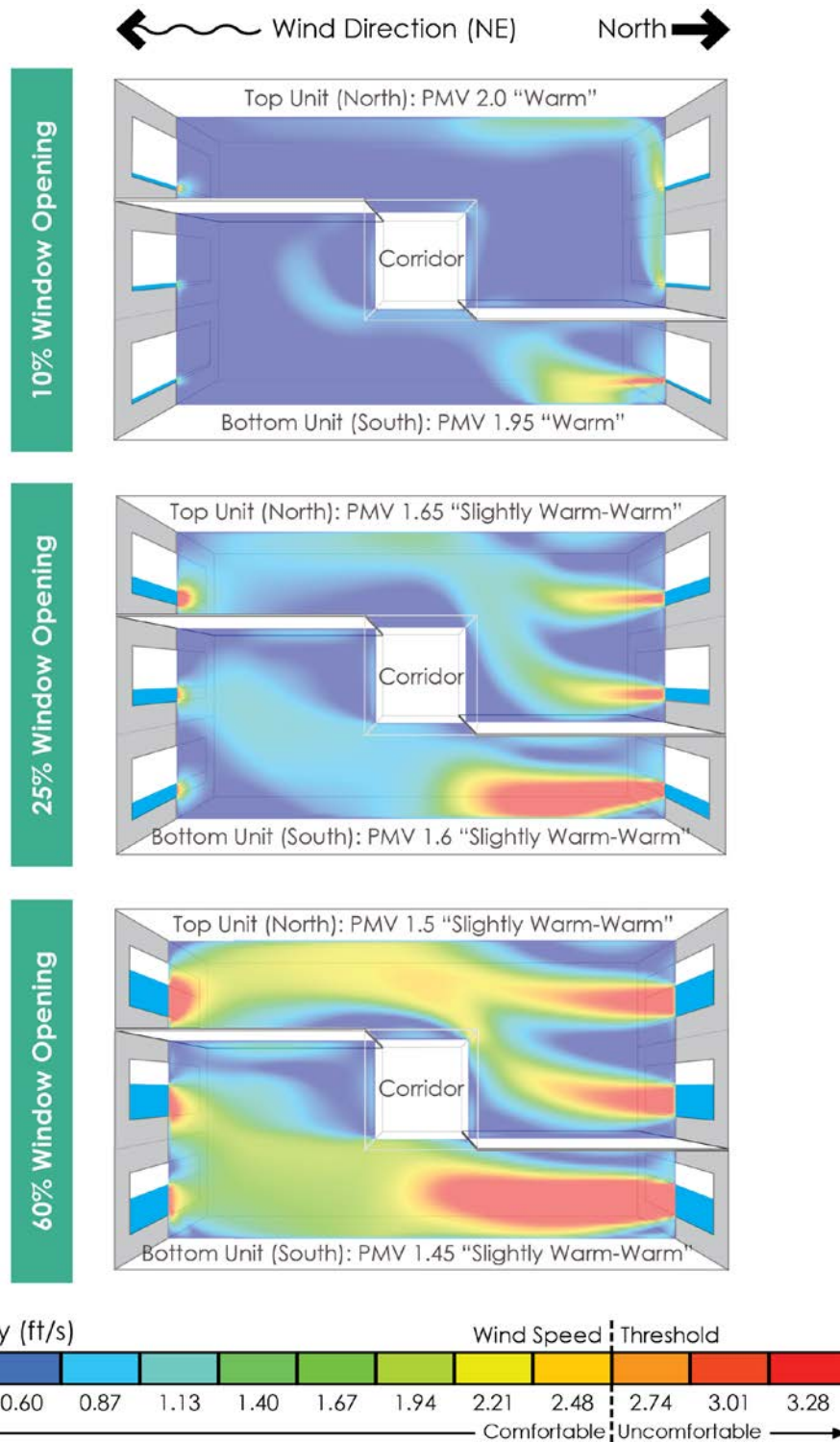

Figure 76. Skip-Stop Double Loaded Corridor (0°) CFD Results on August 26 at 8:00pm. The bottom unit performed slightly better than the top relative to PMV thermal sensations but not air speed as there was a greater area considered a nuisance depending on proximity to the window opening.

10.2.4 Skip-Stop Double Loaded Corridor (180°)

Due to the skip-stop DLC unique spatial configuration a separate analysis was done with the model oriented 180 degrees. The resulting orientation placed the façade with great openings in the bottom unit to the high pressure facade rather than the low pressure facade as shown in the previous results. The intent of this analysis was to further understand the effects of the window opening locations relative to the high versus low pressure façade.

The bulk air flow results, section 10.1.5, indicated that when the façade with greater openings in either top or bottom unit was oriented toward the low pressure façade produced a more comfortable space than the opposite year-round. The visual CFD results demonstrate that the top unit with greater window openings toward the low pressure or leeward façade produced better thermal comfort in terms of PMV thermal sensations than the opposing bottom unit. Although the top unit performed slightly better than the bottom unit in terms of PMV there are pockets of uncomfortable air speeds near the window inlets. The top unit also experienced unequal distribution of air flow and speeds relative to the bottom unit which were steady and consistent.

The geometry with fewer openings on the high pressure façade and greater openings on the low pressure facade had created a venturi effect where air speeds increase in constricted areas and decrease on the opposite (expanded) areas. A similar effect can be seen in the same model in its original orientation but for the bottom unit as was demonstrated in the previous results. It is likely that the small area adjacent to the access corridor in the top unit oriented in this manner would require a ceiling fan to enhance air flow in all cases unless wind directions are coming from the south.

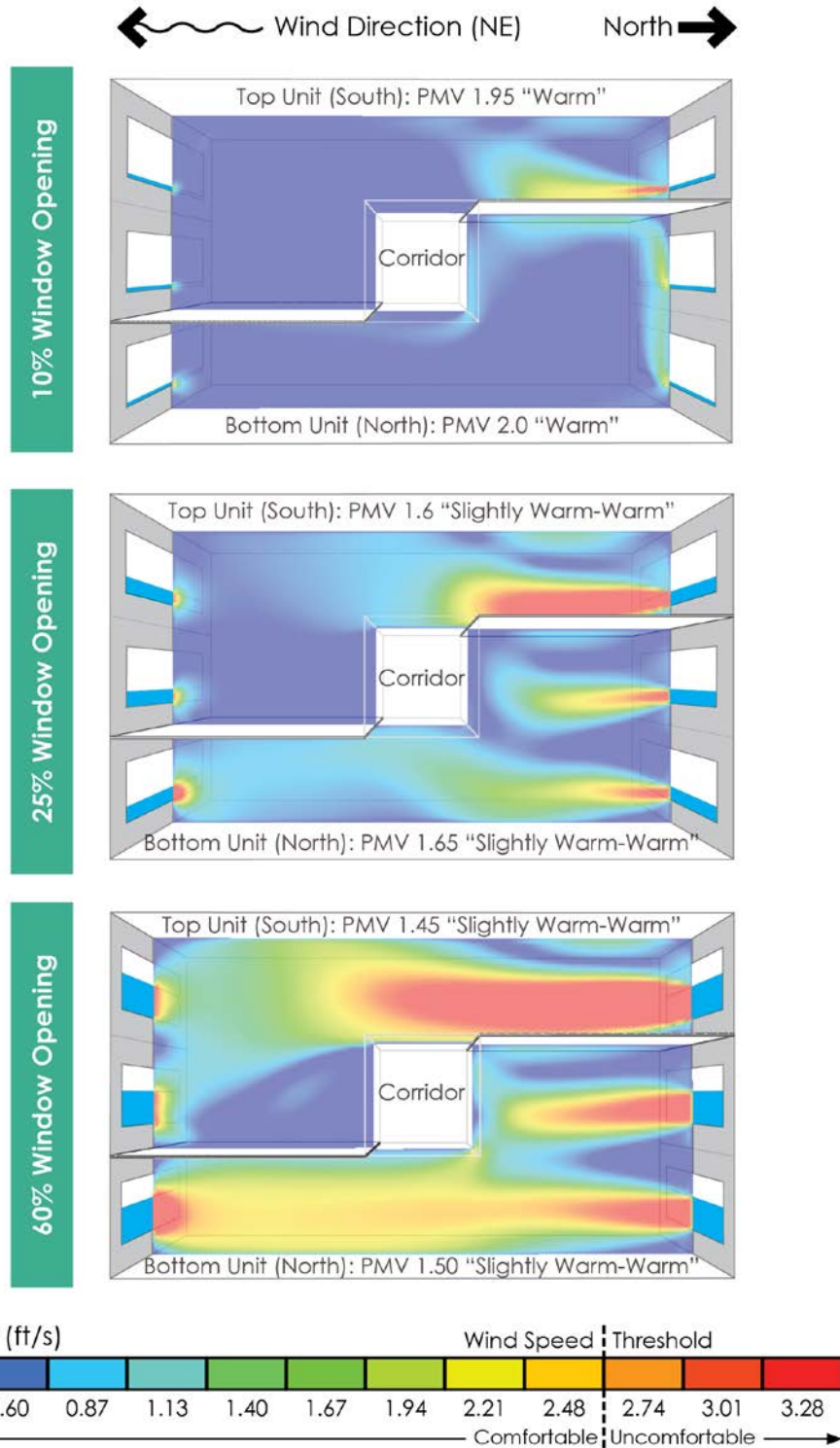

Figure 77. Skip-Stop Double Loaded Corridor (180°) CFD Results on August 26 at 8:00pm. The top unit performed better than the bottom unit in regards to PMV thermal sensations but not in air speed as there was greater area considered a nuisance depending on proximity to window openings.

PART III
RESEARCH SUMMARY

CHAPTER 11

Evaluation and Conclusions

To improve the natural ventilation performance of a high rise residential building, the thermal comfort conditions of a proposed skip-stop double loaded corridor (SSDLC) design was evaluated and compared to a traditional economically preferred double loaded corridor (DLC) and single loaded corridor (SLC) design. The estimate thermal comfort was not as absolute (predicted) but relative (comparative). The proposed SSDLC model improved in thermal comfort compared to the DLC and SLC models in all cases. The SSDLC model significantly improved thermal comfort conditions relative to the DLC model proving to be an efficient solution to problems faced with the double loaded corridor spatial configuration and cross ventilation. Relative to the SLC model, improvement in thermal comfort was moderate.

Bulk air flow modeling was used to estimate thermal comfort of each model relative to each other. It provided insight on the effects of spatial configuration/geometry, shading projection factors, window opening areas, and ceilings fans on thermal comfort. The metric used to determine acceptable thermal comfort was predicted mean vote (PMV) with an upper threshold of +1.5. There is not a great deal of knowledge of how the PMV model relates to thermal comfort zone of naturally ventilated spaces. Therefore, the thermal comfort zone or threshold used for this project in determining acceptable thermal comfort was estimated to reflect one's ability to accept a wider range of thermal sensations when occupying a naturally ventilated space. Thermal conditions rarely dip below PMV -1.5 in Honolulu and were not considered as thermally uncomfortable. Thermal discomfort in Honolulu from which this analysis took into account was on the warmer side of the thermal sensation scale as demonstrated in the first set of analyses.

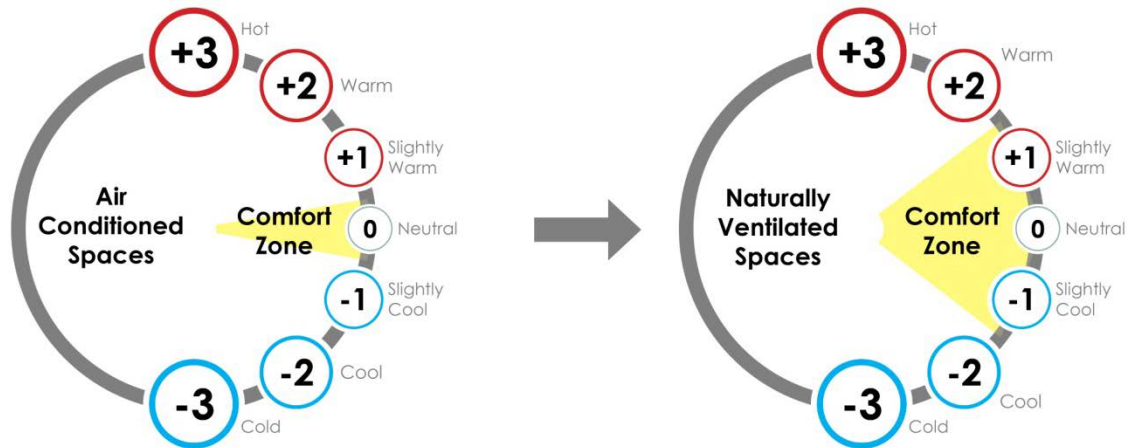

Figure 78. Comparison of the prescribed comfort zone in air conditioned spaces ($-0.5 < \text{comfort} < +0.5$) versus the estimated thermal comfort zone in naturally ventilated spaces ($-1.5 < \text{comfort} < +1.5$) used to determine acceptable thermal comfort in each naturally ventilated spatial configuration model.

The effects of spatial geometry on air flow and thermal comfort were illustrated in the bulk air flow and computational fluid dynamic modeling results. Other design elements such as shading projection factors, window opening areas, and local air speeds were also important in the thermal comfort condition of each spatial configuration model. Strategic design considerations toward minimizing heat gain and maximizing ventilation showed potential in significantly reducing the need for air conditioning thus reducing building energy consumption. A less energy intensive approach in providing acceptable thermal comfort in naturally ventilated spaces is a challenge for any architect as design elements will need to be a balance of both function and aesthetic. This chapter describes the trade-offs with each design element in a tropical hot and humid condition based on key findings of the research. These findings will be beneficial to architects practicing in Honolulu or other tropical cities around the world.

11.1 Orientation to Sun and Wind

Baseline models with 0 shading projection factors, 15% window openings, and 0.33 ft/s local air speeds demonstrated right off the back how important spatial geometry was on natural ventilation and thermal comfort. The SSDLC model performed best with 26% of the year being uncomfortable compared to the SLC (35%) and DLC

(58%) models. Breaking down these results further illustrated the thermal sensations experienced in each model. Under the same conditions, the thermal sensations experienced in the SSDLC model dipped below neutral and into the cooler side of the scale about 22% of the year. Similar conditions can be seen in the other models but are not as evident. Cooler conditions in a warm/hot and humid climate such as Honolulu are generally more favorable thus providing the SSDLC an advantage over other models.

Minimizing heat gain as much as possible is one of two main design principles found in tropical vernacular architecture as seen with large overhangs and shading devices. Shading reduces solar exposure on building façade penetration of direct sun light thereby reducing internal heat gain and energy loads on HVAC systems in removal of heat from the space. Manipulation of shading projection factors (PF) improved thermal comfort in all models, however not as significant for north and south orientations only.

Thermal comfort improvements were also not as significant due to the center locations of each unit relative to the building mass it resided in. Units that were located on the east/west facing sides or top level of the building would have resulted in different thermal comfort conditions due to greater exposure of solar radiation. In any case, these units require special attention to building envelope design such as wall insulation with higher R-value or vertical shading devices toward east/west.

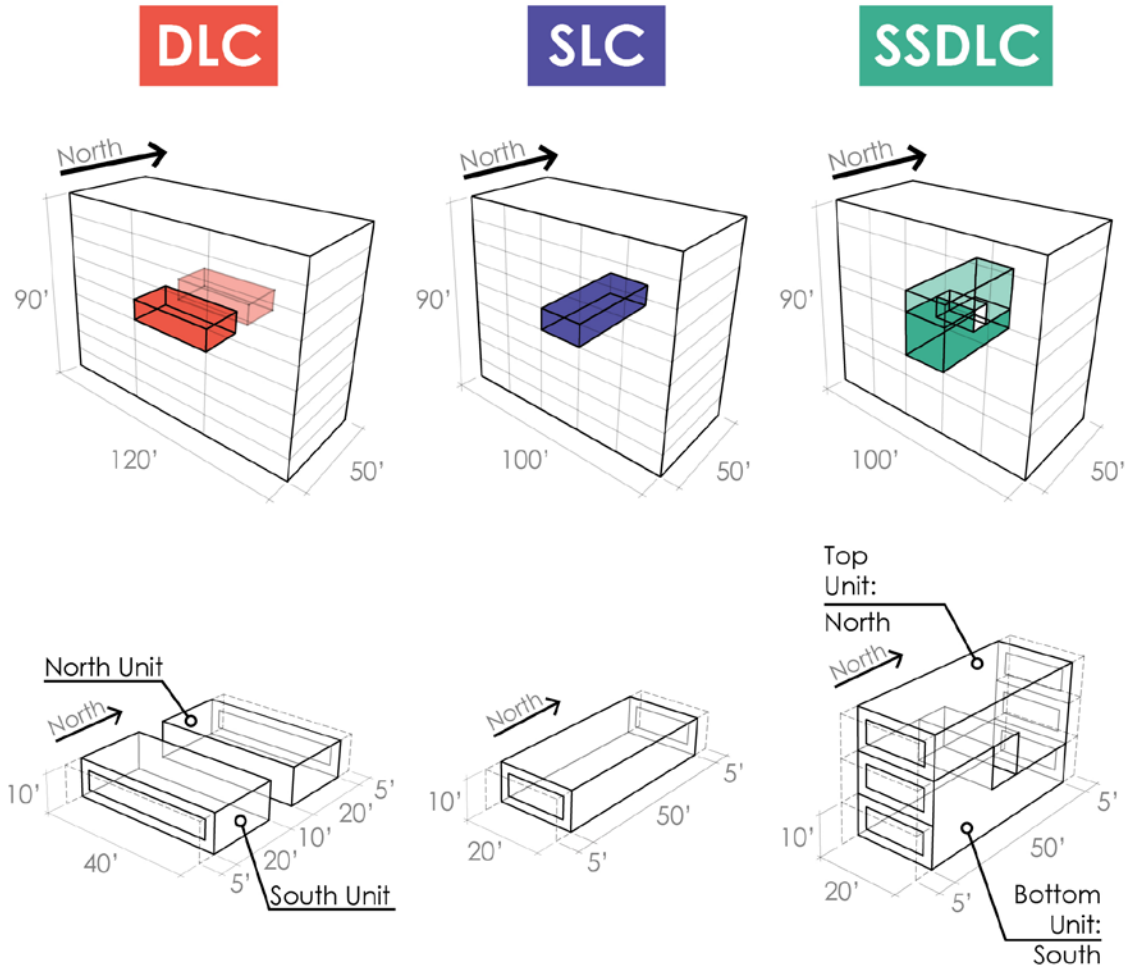

Figure 79. Orientation of each spatial configuration model relative to the sun exposure.

The SSDLC model outperformed the other two with thermal discomfort occurring 18% of the year relative to the SLC (31%) and DLC (53%) models when assigned a projection factor of 0.66 (5'-0" horizontal overhang). With the same projection factor the reduction in thermal discomfort relative to having no shading devices remain small with 4-6% for all models. The strategic orientation of each building mass and corresponding model unit's minimized potential heat gain as much as possible. Opaque facades were oriented east/west blocking out low angle sun exposure occurring early mornings and late afternoons. Façade openings were oriented north and south providing opportunity for effective shading devices as well as harnessing north-east predominant wind patterns.

The north unit of the DLC model performed better than south as expected in all cases. South facing units, due to the location of this analysis, experienced higher solar radiation and therefore resulted in higher thermal discomfort than north facing units. However, that was not the case for the SSDLC model. Both north and south facing units of the SSDLC model resulted in identical thermal comfort conditions when assigned a projection factor of 0 and 0.33. When assigned a projection factor of 0.66 the south facing unit performed 2% better than the north. This suggests that projection factor alone was not only the cause of this result but spatial configuration relative to air flow which was further examined in SSDLC orientation analysis and CFD modeling.

Each model was fortunate enough to take advantage of this ideal orientation for not only shading opportunities but harnessing predominant wind patterns. North facades were oriented 45 degrees from the north-east and east-north-east predominant winds. DBEDT and other sources recommend orienting a space with openings on opposite walls 45 degrees from the predominant wind direction.¹¹⁹ The resulting orientation relative to wind direction is said to improve air flow by 20%. There is an opportunity to test the validity of this statement with further research by examining the effects of various façade orientations relative to predominant wind patterns. The results will be beneficial for microclimate-based design relative to omnidirectional wind patterns in hot and humid conditions.

The tested models, simulated in Honolulu, worked well as opaque facades were oriented east/west blocking low angle sun exposure and window openings oriented north/south harnessing north-east predominant winds. However, this ideal orientation may not work well in other locations. Omni wind directions can greatly affect the orientation of a space in maximizing ventilation. Designing with predominant wind patterns in mind may hinder the orientation of a space in minimizing heat gain. Site constraints could also hinder an architect's ability to strategically orient a building therefore consider each individual façade design relative to the sun and wind patterns simultaneously. At this point building designers should ask themselves, what is more important, orientation relative to the sun or wind? It is not ideal to rely solely on predominant wind patterns for natural ventilation but rather architects should design for the best case scenario based on microclimate conditions the building resides in.

¹¹⁹ (DBEDT 2001)

11.2 Window Openings and Ceiling Fans

Increase window opening area proved to be the most effective in reducing thermal discomfort compared to modifications of shading projection factors and increase local air speed. The DLC model benefited the most with each incremental increase in window opening area – 21% reduction in thermal discomfort with 25% window opening and 32% reduction with 60%. Greater window opening area resulted in better air exchange thus improving air flow and thermal comfort within the DLC model. The DLC model was still the least comfortable of the three with thermal discomfort occurring 21% of the year with 60% window opening compared to the SLC (15%) and SSDLC (11%) models with the same conditions.

Although 60% window opening area showed the greatest improvement in thermal comfort there is still the issue of occupant safety. It is more than likely 60% window opening area would not be allowed for a high rise building envelope as someone could easily fall out. As a result, operable windows of many high rise buildings do not open more than a few inches (<10% opening area) in an attempt to maximize occupant safety.

Window opening area at 10% reduced each models' ability to passively ventilate using wind-driven ventilation resulting in higher annual hours of thermal discomfort. Providing low speed, high volume ceiling fans in these models produced the necessary air speeds for improved thermal comfort. The cooling effect of increased local air speeds in any model was more significant when window opening areas were at its smallest. Increasing local air speed in the SLC model to 2.33 ft/s with a 10% window opening area reduced annual thermal discomfort by 14% compared to 6% with a 60% window opening area.

Increasing local air speed in a model to 2.33 ft/s with 10% window opening area can produce similar cooling effects compared to having a local air speed of 0.33 ft/s (calm) and 60% window opening area in the same model. The results in figure 80 illustrate these conditions in the SLC model. Similar results can be seen in the SSDLC model under the same conditions in figure 81. The DLC model demonstrates different results most likely due to single-sided ventilation associated with this configuration.

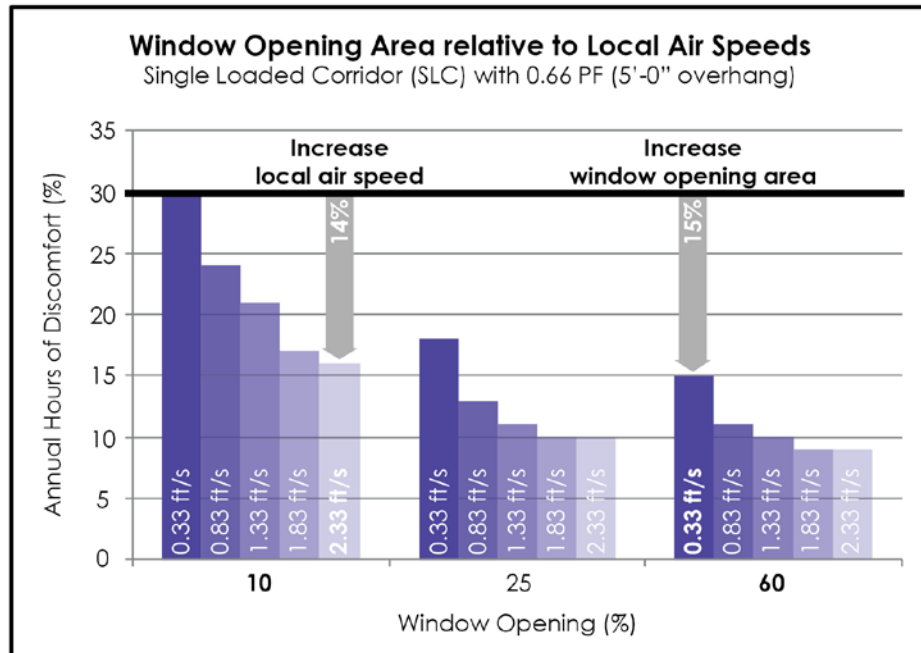

Figure 80. By increasing local air speed to 2.33 ft/s in the single loaded corridor model assigned a 10% window opening area resulted in thermal discomfort 16% out of the year in comparison to the same model with 0.33 ft/s local air speed and 60% window opening area resulted in thermal discomfort 15% of the year.

This is an important key finding as apartment units with restricted window opening area associated with high rise building envelopes could still benefit from natural ventilation cooling while providing occupant safety simply with the addition of a low speed, high volume ceiling fan. Most importantly, thermal comfort is provided utilizing an approach that is less energy intensive than traditional HVAC systems. Regardless, providing operable windows and ceiling fans for occupant control of their thermal environment allows for personalized comfort.

Providing large window openings is not always the solution for natural ventilation. Windows with the ability to open 60% produced higher air speeds that became a nuisance as illustrated in the CFD results. This effect is increased for apartment units located on higher floors as a result of vertical wind speed gradient. Apartment units closer to ground level generally experience lower air speeds and ventilation rates making 60% window opening area more applicable for high density *low-rise* residential building typologies.

			DLC			SLC			SSDLC		
			Opening Area (%)			Opening Area (%)			Opening Area (%)		
			10	25	60	10	25	60	10	25	60
Local Air Speed (ft/s)	0.33	North	50	29	19	31	18	15	20	14	12
		South	53	32	21				18	13	11
	0.83	North	43	22	15	24	13	11	16	11	10
		South	46	24	17				14	10	9
	1.33	North	37	18	13	21	11	10	13	9	9
		South	40	20	15				12	8	7
	1.83	North	34	16	12	17	10	9	11	9	8
		South	37	19	14				10	7	7
	2.33	North	32	15	11	16	10	9	11	8	7
		South	35	17	13				9	7	6
	2.83	North	31	14	11	15	9	8	10	8	7
		South	34	16	13				9	6	6
	3.28	North	29	14	11	14	9	8	10	8	7
		South	32	16	12				8	6	5

Figure 81. Parametric results - window opening area relative to local air speeds. Numbers in the colored boxes represent the percent of annual hours of thermal discomfort. Shading projection factors in these models were set at 0.66 (5'-0 overhang depth). The cooling effect of increase local air speed in the SLC and SSDLC models with 10% window opening area resulted in similar annual hours of thermal discomfort compared to simply having a 60% window opening area in the same models. Single-sided ventilation associated with the DLC model was likely the result of a larger delta in thermal comfort conditions as illustrated above.

Low speed, high volume ceiling fans are beneficial in providing comfort on days with little to no wind since natural ventilation is generally wind-driven. In the absence of a ceiling fan, buoyancy-driven ventilation would be helpful but requires high ceilings in order to effectively enhance comfort. The SSDLC model reduced annual thermal discomfort likely due to the double height ceiling space relative to the single height ceiling SLC and DLC models.

Increase local air speed whether it be opening a window to harness wind or utilizing a ceiling fan reduced thermal discomfort in the naturally ventilated configuration models residing in a tropical hot and humid climate. Window openings affect ceiling fan efficiency in producing the necessary pressure difference in the space for induced air flow as illustrated in figure 81. Figure 82 illustrates the perceived cooling effect of air speed on thermal comfort relative to the psychometric chart. It demonstrates the expansion of the standard thermal comfort zone with introduction of increase air speeds. Air speeds as low as 1.33 ft/s has the ability to reduce the perceived air temperature by 4 degrees Fahrenheit.

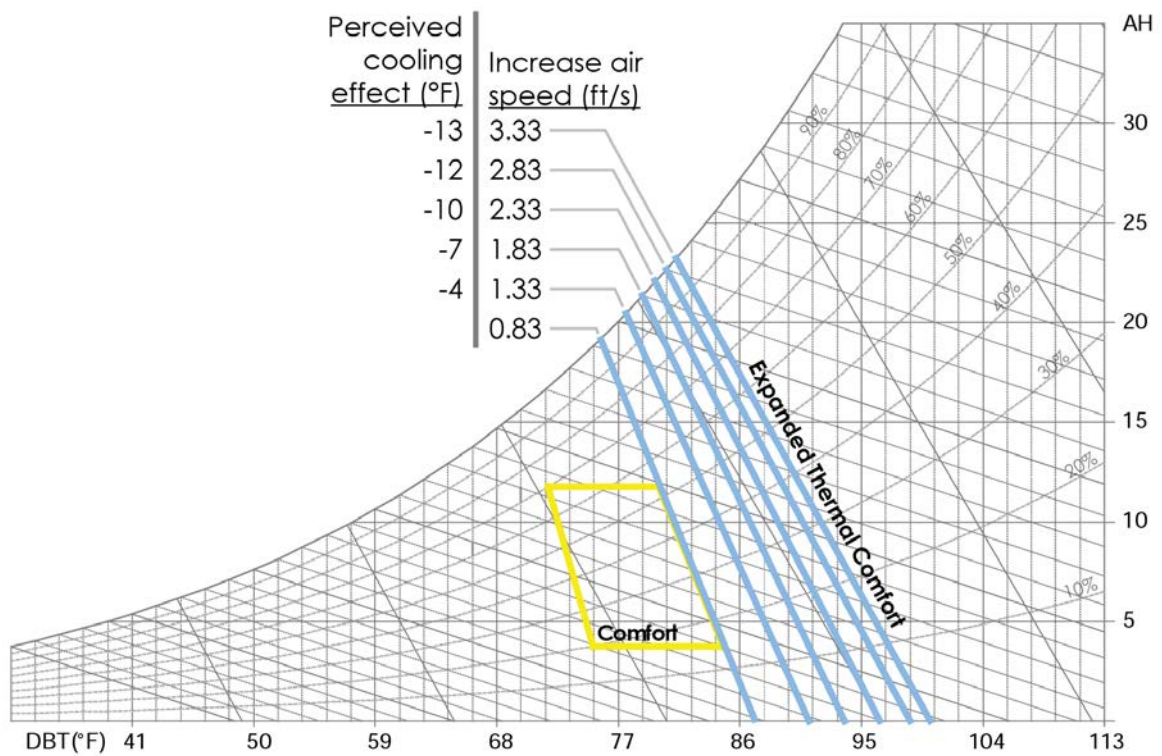

Figure 82. Increased air speeds on perceived thermal comfort. The cooling effect of increased air speeds, based on the speeds used for the parametric analyses, was able to incrementally expand the thermal comfort zone compensating for higher temperature and humidity.

Source: *Mechanical and Electrical Equipment for Building*, redrawn by author

11.3 Airflow relative to Spatial Configuration

A side-by-side visual examination of the air flow patterns relative to the three models – double loaded corridor (DLC), single loaded corridor (SLC), and skip-stop double loaded corridor (SSDLC in 0° orientation) – was the fundamental intent of this project as it demonstrates the effects of spatial configuration on air flow and thermal comfort. Placement of window openings as well as window opening area was crucial to the ventilation performance of any spatial configuration. Manipulating these design characteristics alone affected the efficiency of wind-driven ventilation and potential for buoyancy-driven ventilation.

The DLC model lacks the ability to use cross ventilation resulting in low internal air speeds due to the access corridor acting as a barrier to air flow. The visual results demonstrate the impacts of double-sided ventilation on air flow relative to single-sided ventilation as seen in the DLC model. Single-sided ventilation associated with the spatial configuration was simply not enough to provide the necessary pressure difference along a single façade for induced air flow. Thermal comfort improves with additional window openings as in the case with the SLC and SSDLC models. The SLC and SSDLC model effectively utilizes cross ventilation as air is driven through the space by pressure differences on windward and leeward façade openings. SSDLC spatial configuration performed best in all parametric analyses as it was able to provide both greater window opening areas along with double-sided ventilation for effective wind-driven ventilation and double height ceilings for buoyancy-driven ventilation. Figure 83 compares each model assigned a 25% window opening area with corresponding thermal sensations represented in PMV. Refer to Appendix B for all CFD visual results.

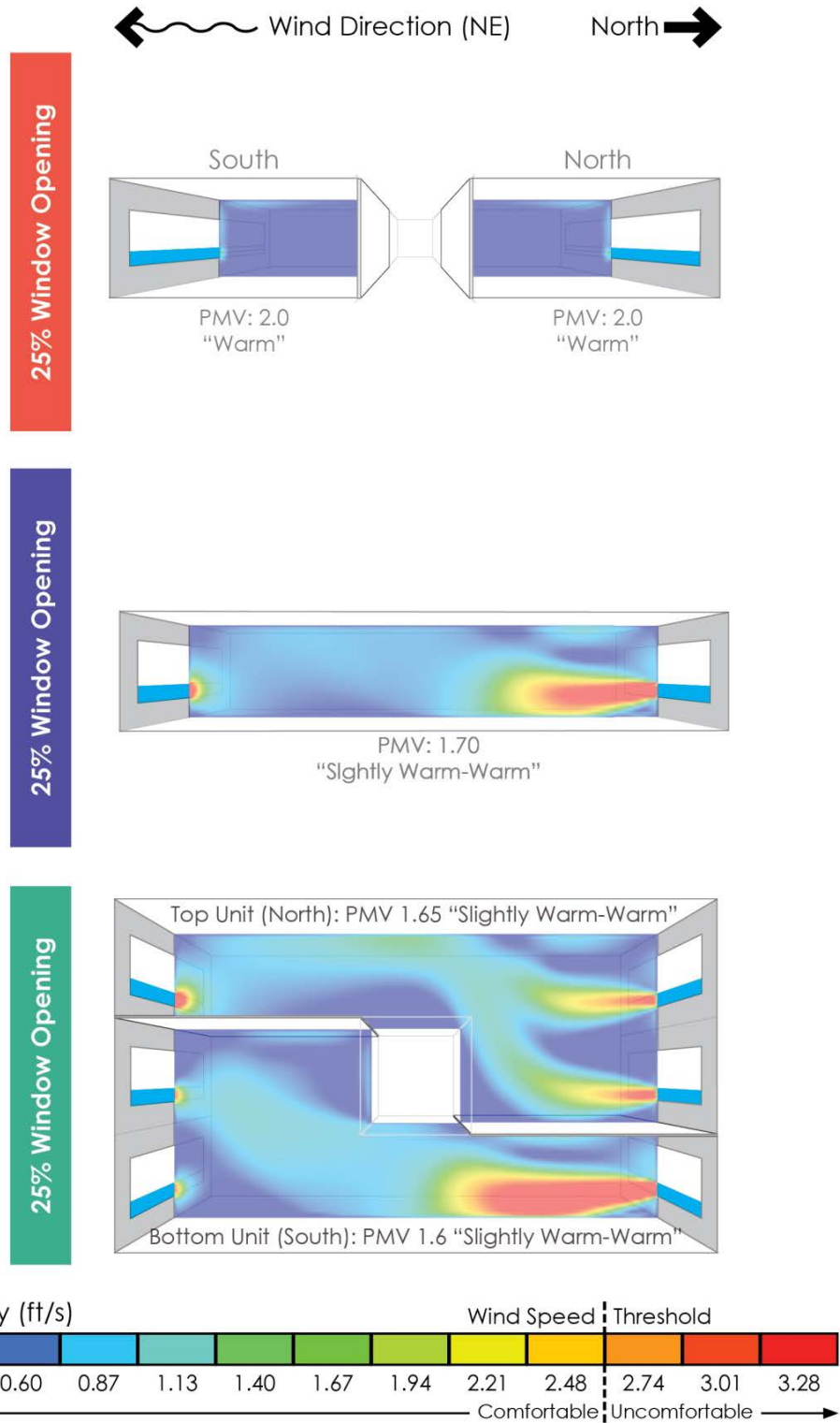

Figure 83. Side-by-side examination of air flow patterns relative to each model assigned a 25% window opening area on August 26 at 8:00pm.

The issue of ADA (Americans with Disabilities Act) access is apparent despite the SSDLC model being a viable solution to the DLC configuration and cross ventilation conundrum. Each unit of a SSDLC configuration requires an elevator or lift to gain access to the upper or lower levels to be ADA compliant. This physical element will have an effect on design layouts and air flow in the unit. However, the playfulness of utilizing various spatial configuration units in a single building accommodates various user groups similarly to the design intentions of the Unité d’Habitation buildings by Le Corbusier. As a result, both ADA compliant and SSDLC units reside in the same building.



Figure 84. Skip-stop spatial configuration with other various types of apartment units in a single building accommodating a wide variety of user groups.

Source: *The Good Solutions Guide for Apartment*, Auckland City Council

With a SSDLC configuration an access corridor is only required at every other floor, hence the term “skip-stop.” The SSDLC model provides more usable floor area per unit relative to circulation space via access corridor. Both SLC and DLC configurations

are good at space planning in maximizing unit count but is subject to greater unusable circulation area. The access corridor location on either side of the SLC model could also pose a problem. If unexposed, for fire safety, the unit will not be able to cross ventilate properly surrendering to single-sided ventilation. If exposed, cross ventilation will be possible if window/doors are open to the access corridor side of the building which poses a problem for privacy and security. With the SSDLC model occupants will have the privacy of a DLC configuration and cross ventilation advantages of a SLC configuration.

These simplified spatial configuration models have the opportunity to be manipulated for functional design layouts catering to various user groups. Introducing internal partitions to divide up spaces will affect airflow and thus placement must be carefully considered. The unique spatial configuration of the skip-stop provides opportunities to produce interesting design layouts not typical in double loaded corridor high rise buildings. Architects must balance both function and aesthetics while considering multiple aspects of space design in respect to not only its occupants but sun and wind in minimizing heat gain and maximizing ventilation.

11.4 Units of a Skip-Stop Double Loaded Corridor Configuration

Orientation of individual units in each model was important in the effectiveness in providing efficient shading opportunities to minimize solar heat gain and maximizing ventilation. Window opening areas and increase local air speeds via ceiling fan were also important in maximizing ventilation in each model. What was perhaps most interesting was the SSDLC bulk air flow results. Orienting the double height ceiling space toward the low pressure or leeward façade resulted in fewer annual hours of thermal discomfort compared to the opposing unit with opposite conditions whether it was the top or bottom in the spatial configuration. CFD results was consistent with bulk air flow results confirming fewer openings on the high pressure façade (windward) and greater openings on the low pressure façade (leeward) produced better thermal comfort conditions relative to PMV thermal sensations experienced on August 26 at 8:00pm. This is illustrated in figure 85. High/low pressure facades vary from location to location therefore, careful attention must be given not only to the orientation relative to the predominant wind patterns in maximizing ventilation but sun exposure in minimizing heat gain.

Despite producing slightly better PMV thermal sensations the units with these conditions produced a greater area of high air speeds considered a nuisance depending on the proximity to window openings. Bulk air flow modeling was limited in recognizing this. Locations of window openings relative to high/low pressure façade produced a venturi effect where air was constricted and sped up on the side with fewer openings. The resulting air speed nearest the window opening exceeded the comfort threshold of 2.5 ft/s. Operable windows provide occupant control in mitigating these conditions to meet acceptable comfort.

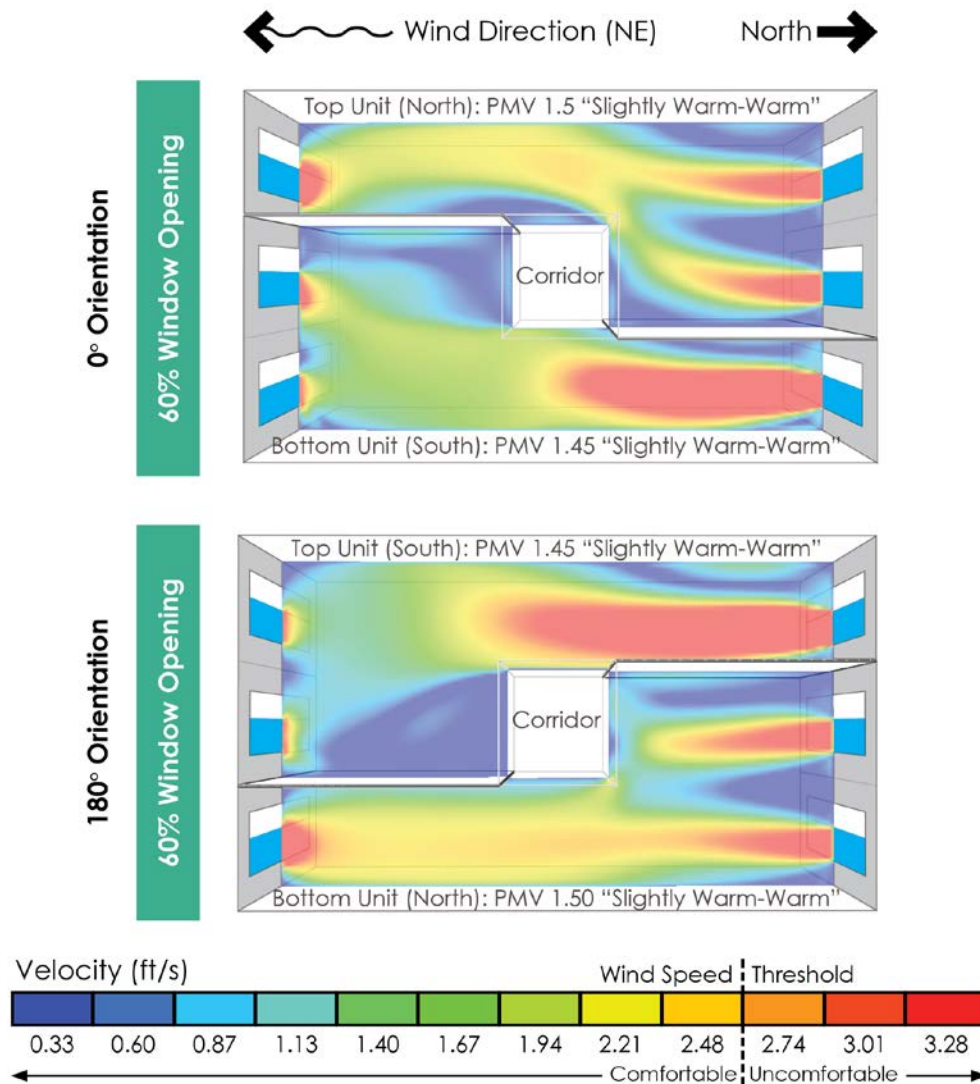

Figure 85. CFD comparison of the SSDLC model in two orientations.

Although it is not illustrated in CFD modeling, the SSDLC model, with its double height ceiling space has the ability to not only utilize wind-driven cross ventilation but stack ventilation where warmer air rises and exits the space while pulling cooler, denser air from below. This effect would be helpful on days with little to no wind compared to the SLC model which the primary driving force for providing passive ventilation is mainly caused by wind. A greater ceiling height can produce a greater stack effect as in the case of the SSDLC model relative to the other models. The SDLC model was able to provide greater window openings in comparison to the other models resulting in better air flow. The combination of both greater window openings for optimal wind-driven ventilation and a double height ceiling for buoyancy-driven ventilation allowed the SSDLC model to perform better than the SLC and DLC model.

CHAPTER 12

A Potential Model for Future Tropical Built Environments

Can the skip-stop doubled loaded corridor (SSDLC) spatial configuration be a viable solution to the cross ventilation and double loaded corridor (DLC) dilemma? How does this spatial configuration from the Mediterranean perform in a tropical climate? Can this spatial geometry designed for taking advantage of heat gain be used to take advantage of cross ventilation? These questions fundamentally led to the development of this research project which utilized simulation tools to obtain estimated data on air flow and thermal comfort of a SSDLC model relative to a DLC and SLC model. This chapter discusses the basic principles that made the SSDLC model outperform the others and how they can best be applied to practice in sculpting naturally ventilated spaces for improved thermal comfort and reduction in building energy consumption. All bulk air flow results relative to air flow and thermal comfort obtained from this project is represented in the form of a matrix diagram in Appendix A. All CFD results are presented in Appendix B.

12.1 Importance of an Adaptive Environment

The Intergovernmental Panel on Climate Change (IPCC) concluded that “the buildings sector presents the biggest potential for deep and fast CO₂ emission reductions on a cost-effective basis.” However, this assessment was “premised exclusively on technical (engineering) measures, but ignored completely the behavioral and lifestyle dimensions of energy consumption in the buildings sector.”¹²⁰ Behavioral change in buildings, such as manipulation of window openings and local air speeds via ceiling fans, can have a great effect on not only thermal comfort in naturally ventilated spaces but in energy efficiency and greenhouse gas (GHG) emission reductions. Many believe that “building designers are beginning to shift their attention to how they can widen the range of opportunities available in a building to provide comfort for occupants. This in turn has re-awakened an interest in the role of natural ventilation in the provision of comfort.”¹²¹

¹²⁰ (de Dear, Cândido, et al. 2010)

¹²¹ Ibid

Designing an adaptive naturally ventilated environment where its occupants can manipulate physical elements to achieve acceptable thermal comfort is the key to reducing building energy consumption in future tropical buildings. The psychological effect of providing an operable window and ceiling fan to manipulate air flow expands one's thermal comfort zone thereby being able to accept a wider range of temperatures and environmental conditions. Long-term exposure to the natural environment, through acclimatization, invokes behavioral changes based on one's preference and expectations of the variations in the environment. Providing an adaptive environment provides personalized comfort that satisfies the needs of any individual.



Figure 86. Adaptive behavior – switching on a fan, opening a window, shading a window – for thermal comfort in response to hot and humid conditions.

Source: *Mechanical and Electrical Equipment for Buildings*

Switches, as defined by Christian Norberg-Schulz, allow the building envelope to respond to the external climatic conditions, building and occupant needs, and available

resources.¹²² *Switches* include but are not limited to operable windows and shading. The efficiency of *switches* is dependent on those that control it, the occupants. A great deal of knowledge and occupant cooperation is required to ensure optimal performance of these types of building envelopes and building energy consumption as a whole. A tropical vernacular building envelope acts basically as a giant *switch*. Because outdoor conditions are close to the desired indoor conditions the building envelope begins as an open frame structure where the skin is designed to be flexible as to control the incoming environmental forces like sun and wind.¹²³ Many operable windows and screens are generally provided for occupant control over their indoor environment. Modification to the building envelope controls ventilation for passive cooling and removal of internal heat gain.

The building envelope of many modern tropical tall buildings do not function as a *switch*, but rather a *connector* to light, heat and a *barrier* to wind as seen prominent in temperate high rise models. The temperate model works well in the climate it originated from but not in the tropics where opposite conditions are more desirable – maximizing ventilation and minimizing heat gain. A well-designed building envelope in the tropics offers an opportunity to reduce thermal discomfort using natural ventilation and energy loads required to cool with air conditioning.

Air conditioning is still widely used in the tropics, despite positive thermal comfort studies in naturally ventilated spaces, as it reduces both air temperature and relative humidity. Although natural ventilation cooling offers thermal comfort in hot and humid climates there will always be times during the year when thermal comfort is exceeded (hourly conditions, represented as points, that fall outside the natural ventilation zone seen on the psychrometric chart, figure 87). Air conditioning cannot be completely dismissed from tropical architecture as mechanical cooling is required to offset those periods of exceeded thermal comfort that natural ventilation cooling cannot simply provide alone. This mode of operation is otherwise known as mix-mode cooling and ventilation.

¹²² (Grondzik, et al. 2010)

¹²³ Ibid

Psychrometric Chart

Location: Honolulu Intl Arpt, USA
Data Points: 1st January to 31st December
Weekday Times: 00:00-24:00 Hrs
Weekend Times: 00:00-24:00 Hrs
Barometric Pressure: 101.36 kPa
© Weather Tool
Comfort: Natural Ventilation

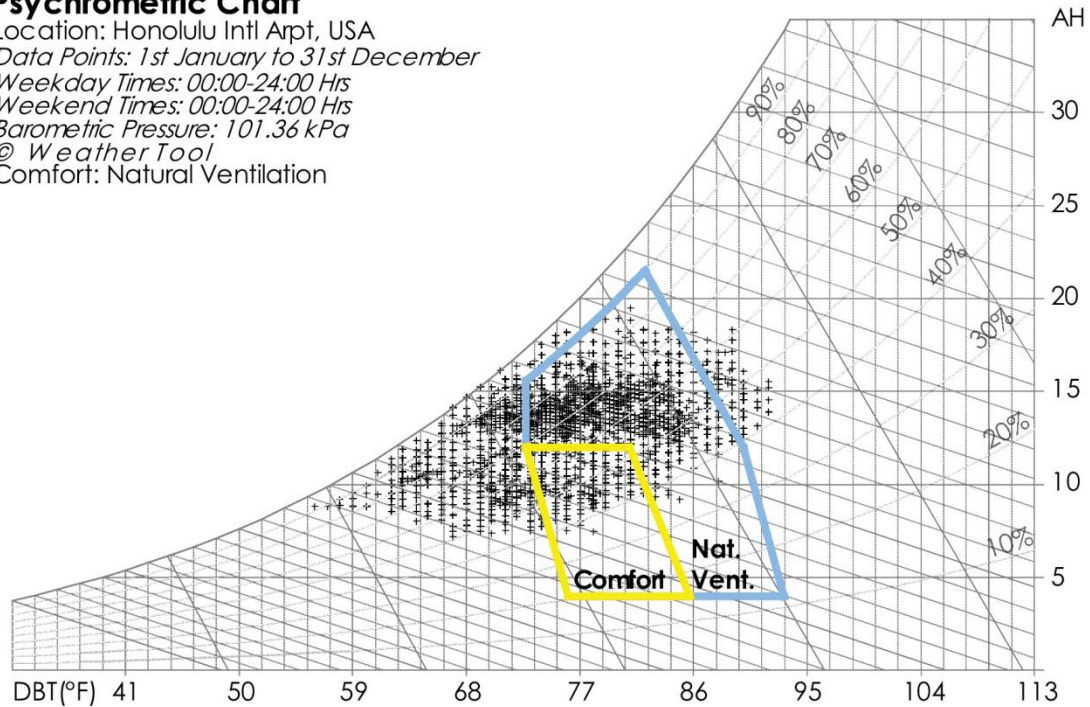

Figure 87. Psychrometric Chart of Honolulu's climate hourly conditions, represented as points, overlaid with the standard thermal comfort zone developed by ASHRAE. Using natural ventilation to provide thermal comfort is viable in Honolulu for a high percentage of the year. Higher air temperature and humidity is acceptable with the introduction of increased air speeds.

Source: Ecotect Analysis 2011 Weather Tool, Honolulu International Airport TMY3 weather file

There is some contradiction to designing for mix-mode cooling and ventilation. Natural ventilation requires large openings in the building façade to maximize ventilation. Air conditioning requires smaller openings or a sealed envelope to ensure regulated control of internal environmental conditions. The challenge is designing a building envelope that works well with both natural and mechanical ventilation and cooling to provide acceptable thermal comfort year-round. This mode of operation reduces the need for air conditioning therefore potentially reducing building energy consumption while providing an environment that meets satisfaction for every individual needs and preferences.

12.2 Sculpting the “Aesthetics of Air”

Sculpting a space to receive, reject, or channel air flow determines the effectiveness of natural ventilation on thermal comfort in a hot and humid climate. Achieving thermal comfort through passive measures in the tropics is challenging. High thermal conditions and relative humidity plays a role in the overall thermal comfort of an individual.¹²⁴ In scientific terms, the body’s ability in losing heat – cooling through perspiration – is greatly decreased as the over saturated air typically found in the tropics can hinder the evaporation of sweat. This leads to unsatisfied comfort as one will continue to experience the hot and “sticky” feeling associated with tropical climates. Natural ventilation cooling is an effective passive solution to aid in thermal comfort in the tropics as higher air speed is used to offset high temperatures and increase evaporation of sweat.¹²⁵

Elongated spatial configurations aid in the effectiveness of cross ventilation. Its orientation to the sun plays a vital role in receiving solar radiation. Shorter opaque facades are orient towards the “direction of the strongest solar radiation” such as East and West.¹²⁶ This reduces low sun exposures that occur during the early morning and late afternoon that would otherwise contribute to significant heat gain and result in thermal discomfort. This may not always play out with the direction of prevailing winds if they are coming from east or west. In any case, architects must consider microclimates as a design driver for naturally ventilated buildings attempting to maximize ventilation while minimizing heat gain at the same time.

Building configurations with long faces toward north/south and short faces toward east/west work well in Honolulu based on climate and geological location. This orientation minimizes heat gain and maximizes ventilation as much as possible. South facades provide effective shading opportunities such as horizontal overhangs while east and west facades block out low angle sun exposure during early morning and late afternoon. Openings on the north façade are orientated 45 degrees from north-east predominant wind patterns. This technique is said to improve air flow by 20%.¹²⁷ Designing for only prevailing wind patterns is not entirely recommended because winds

¹²⁴ (Givoni 1998)

¹²⁵ (Grondzik, et al. 2010)

¹²⁶ Ibid

¹²⁷ (DBEDT 2001)

generally come from all directions year round. Instead architects should design for the best case scenario based on microclimate conditions.

Designers should sculpt the building façade similarly as they would for spatial configuration to effectively receive, reject, or channel air flow into a space. Window opening area and placements effect to ability to passively ventilate efficiently. The research found that having fewer openings on the high pressure or windward façade and greater openings on the low pressure or leeward façade improves air flow. Cross ventilation is optimal when inlets are smaller in area than outlet openings. It is recommended that outlet openings are placed high and low for both cross and stack ventilation.

Minimization or strategic placements of internal partitions ensure these physical elements do not act as barriers to air flow. Transoms above closed doors allow air to flow through multiple spaces without hindering privacy of individual spaces. High ceilings provide opportunities for buoyancy-driven ventilation for improved thermal comfort during days with little to no wind-driven ventilation. High ceilings also provide opportunities for greater window opening areas and improved air flow. The skip-stop double loaded corridor model is a good example of these conditions as it provided both double height ceilings for buoyancy-driven ventilation and greater window opening areas for improved wind-driven ventilation relative to the other single height ceiling models.

Balconies are beneficial not only by providing shade but a buffer space and connection with the outdoors as seen in tropical vernacular architecture. "Balconies that are fully recessed within the overall building form are to be preferred over those that project fully beyond the face of the building."¹²⁸ A balcony provides an opportunity to mitigate high air speeds associated with upper level apartment units being a viable design element for channeling or buffering air flow for high rise building typologies.

Air flow becomes complex in an urban environment. The absolute magnitude of variables is nearly impossible to measure through field validations. Designing for the best case scenario based on microclimate conditions is better achieved with the help of simulation modeling. Bulk air flow and computational fluid dynamic modeling provide

¹²⁸ (Auckland 2007)

building designers with tools that aid in the development of architecture with a focus in natural ventilation and thermal comfort. Bulk air flow modeling provides annual data on thermal comfort and good estimates on the impacts of various design decisions. CFD modeling provides a visual snap shot in time of how these design decisions for natural ventilation effects air flow patterns relative to comfort. It is recommended that these tools be utilized to gain good estimates on air flow and thermal comfort. These estimates are not seen as absolute but relative to other conditions being tested to achieve the best design scenario.

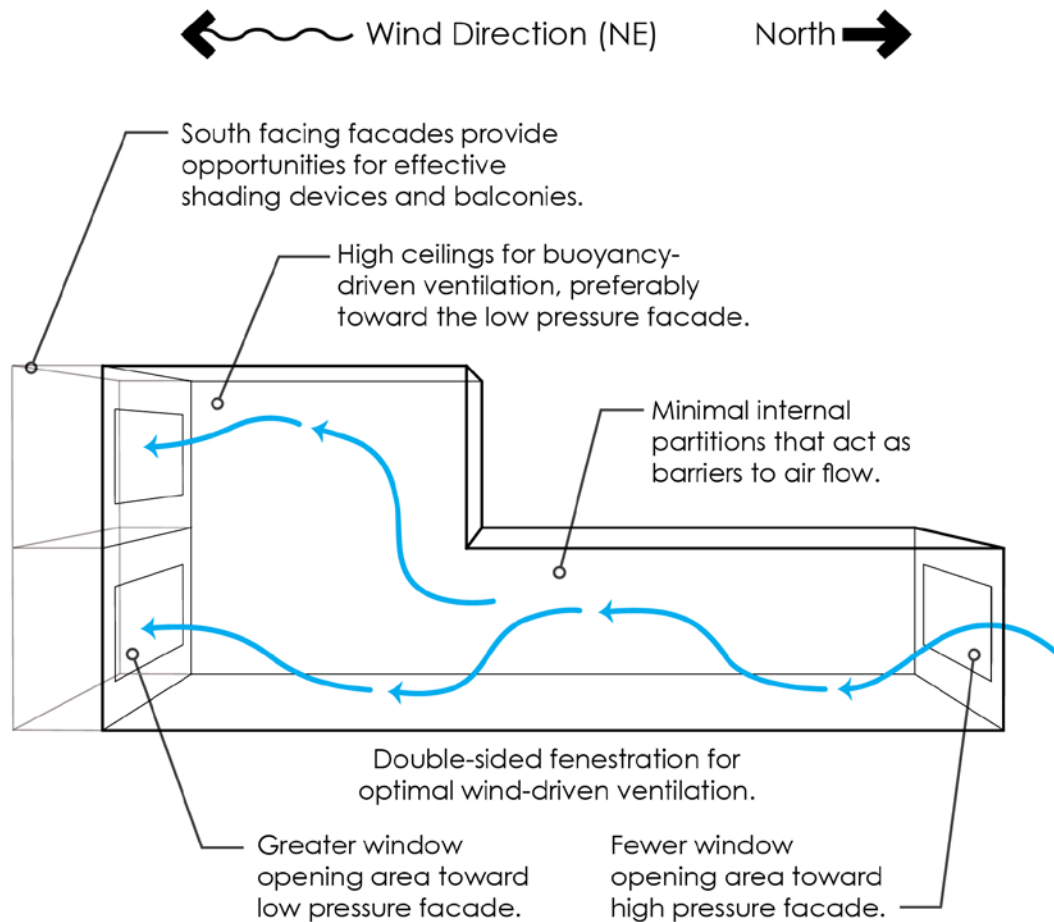

Figure 88. An optimal spatial configuration and building envelope model for natural ventilation in Honolulu based on research findings.

The fundamental principles for designing naturally ventilated buildings in the tropics are minimizing heat gain and maximizing ventilation as much as possible. The

model produced from the research findings consider orientation relative to sun and wind in Honolulu. Both the spatial configuration and building envelope is sculpted relative to solar exposure and predominant wind patterns in Honolulu. This model placed in other geological locations requires modifications based on microclimate conditions.

Le Corbusier once said, "Vernacular is designed by immediate response and has had the fortunate ability to be modified according to suit the occupant's thermal needs, resulting in practical and non-stylistic buildings."¹²⁹ He also quoted, "Today, great architecture is designed by instinct and... in unison with nature. The high technology and complicated materialism is just an enormous mantle, which clothes the idea. Underneath, the instinctive solution is still there." Innovation is built on tradition. The fundamental challenge is how passive design principles and features found in tropical vernacular architecture are reinterpreted, rather than directly mimicked for improved thermal comfort.

¹²⁹ (Bezemer 2008)

APPENDIX A

Bulk Air Flow Results

- Numbers in colored boxes represent percent of annual hours above the thermal comfort threshold of PMV +1.5.
- All windows were left opened year-round.
- Air conditioning was not used.
- Presented results are based on each model assigned a projection factor of 0.66 (5'-0") overhang.
- Projection factor results are not presented here. Refer to Shading Projection Factor section in document for all results.
- Results are relative to window opening areas and local air speeds, e.g. the SLC model with a 25% window opening area and 2.33 ft/s local air speed experienced thermal discomfort 10% of the year.

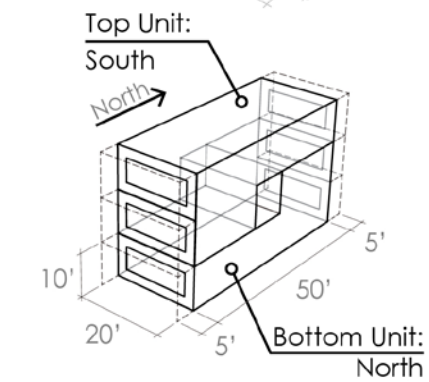
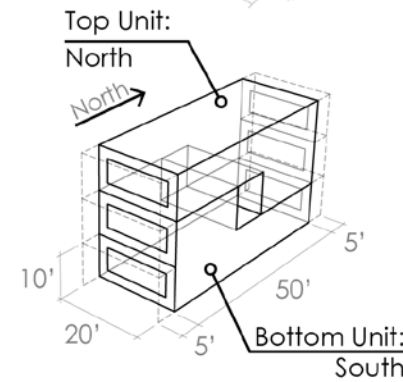
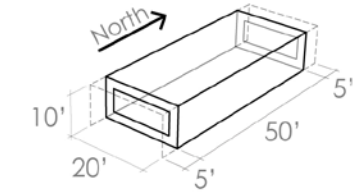
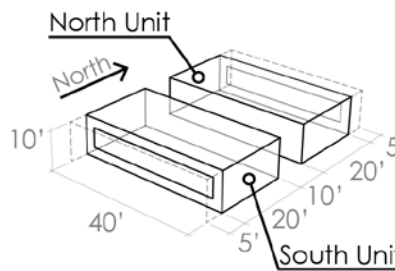
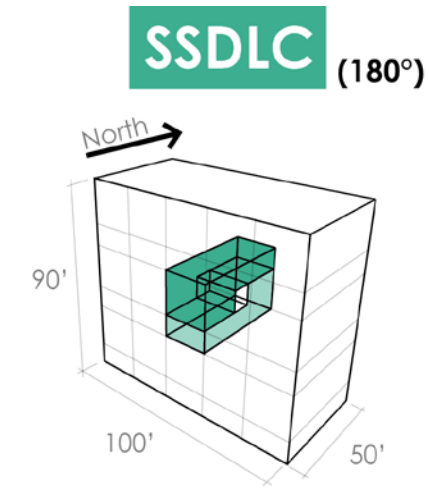
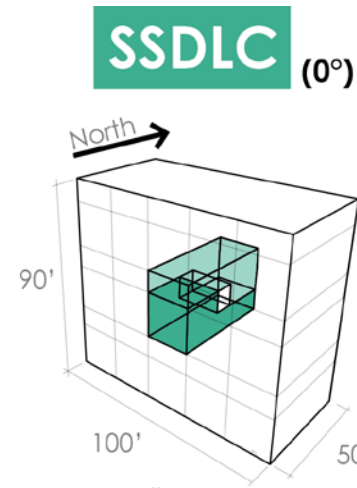
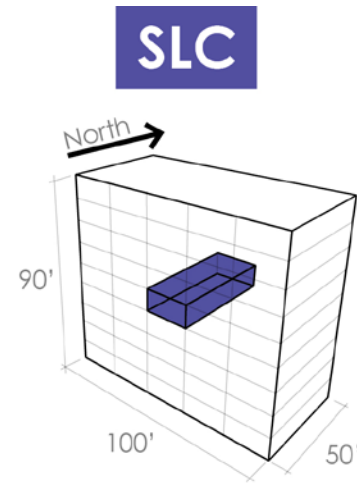
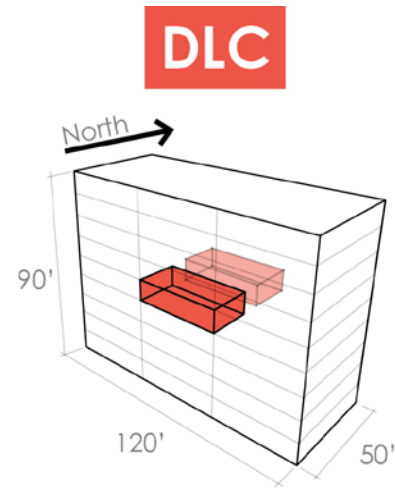

Local Air Speed (ft/s)	Unit	
	North	South
0.33	North	South
	0.83	North
1.33	North	South
	1.83	North
2.33	North	South
	2.83	North
3.28	North	South

DLC			
Opening Area (%)			
	10	25	60
0.33 North	50	29	19
0.33 South	53	32	21
0.83 North	43	22	15
0.83 South	46	24	17
1.33 North	37	18	13
1.33 South	40	20	15
1.83 North	34	16	12
1.83 South	37	19	14
2.33 North	32	15	11
2.33 South	35	17	13
2.83 North	31	14	11
2.83 South	34	16	13
3.28 North	29	14	11
3.28 South	32	16	12

SLC			
Opening Area (%)			
	10	25	60
0.33 North	31	18	15
0.83 North	24	13	11
1.33 North	21	11	10
1.83 North	17	10	9
2.33 North	16	10	9
2.83 North	15	9	8
3.28 North	14	9	8

Top or Bottom Unit	SSDLC		
	Opening Area (%)		
	10	25	60
Top	20	14	12
Bottom	18	13	11
Top	16	11	10
Bottom	14	10	9
Top	13	9	9
Bottom	12	8	7
Top	11	9	8
Bottom	10	7	7
Top	11	8	7
Bottom	9	7	6
Top	10	8	7
Bottom	9	6	6
Top	10	8	7
Bottom	8	6	5

Top or Bottom Unit	SSDLC (180°)		
	Opening Area (%)		
	10	25	60
Bottom	18	12	11
Top	21	14	13
Bottom	14	9	8
Top	16	11	10
Bottom	12	8	7
Top	13	9	9
Bottom	10	7	6
Top	12	9	8
Bottom	9	6	6
Top	11	8	7
Bottom	8	6	5
Top	10	8	7
Bottom	8	6	5
Top	10	8	7

APPENDIX B

DLC

SLC

SSDLC (0°)

SSDLC (180°)

10% Window Opening

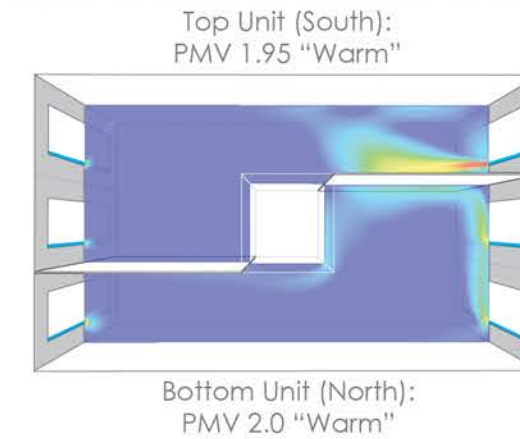
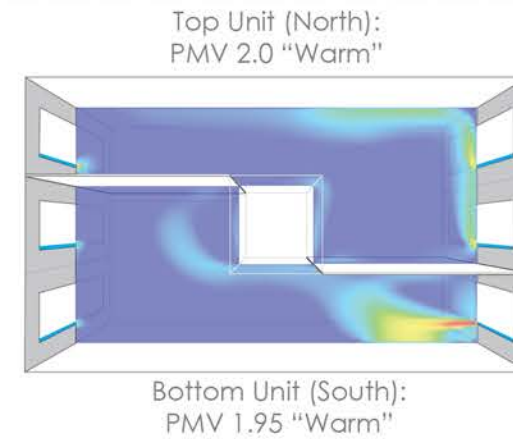
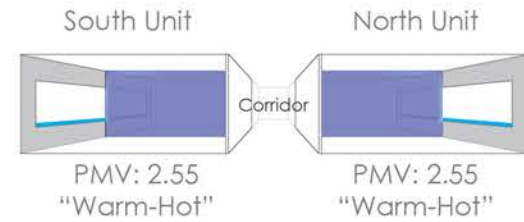

25% Window Opening

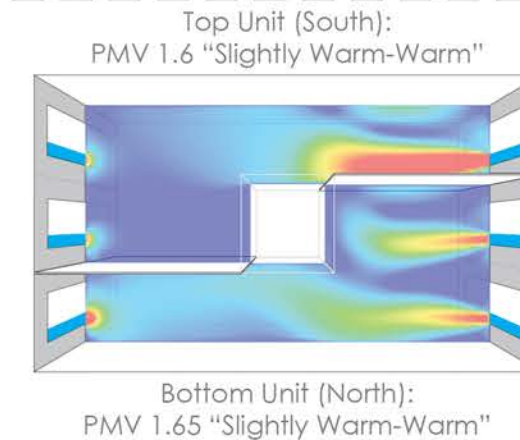
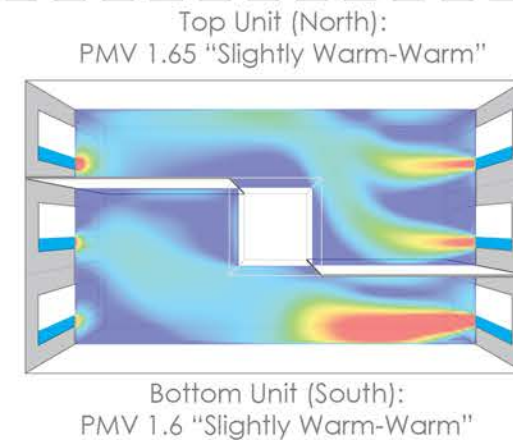
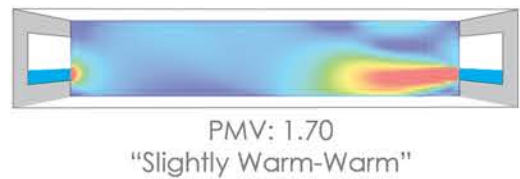
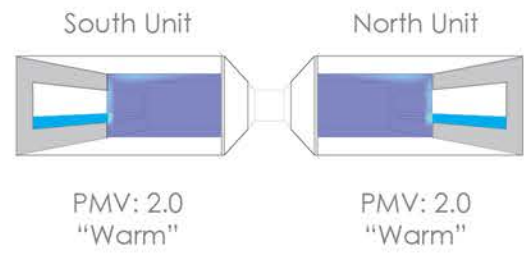

60% Window Opening

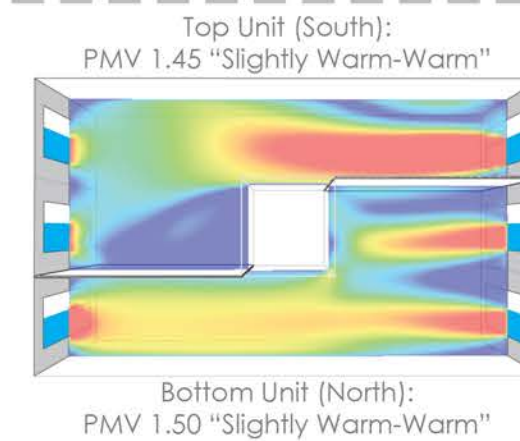
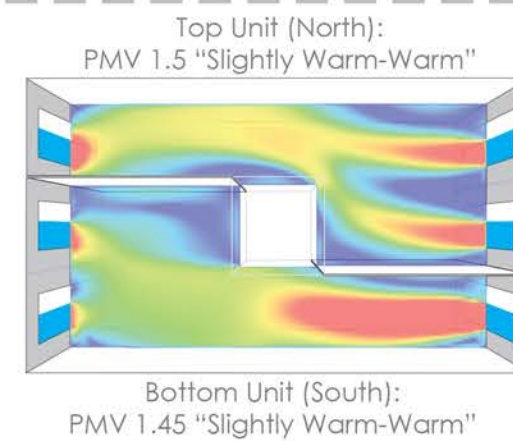
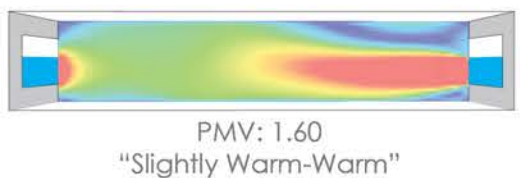
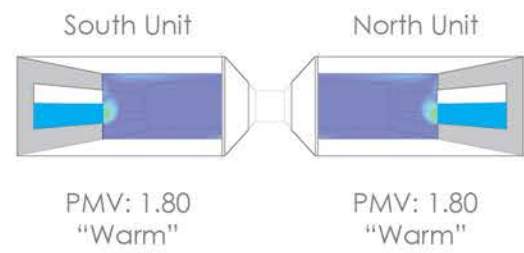

Computational Fluid Dynamic (CFD) Results

← Wind Direction (NE)

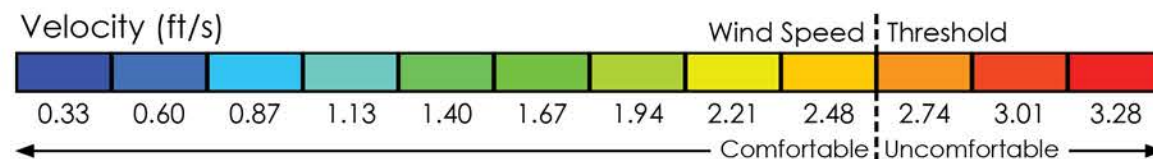

North →

BIBLIOGRAPHY/REFERENCES

AIA. *An Architect's Guide to Integrating Energy Modeling in the Design Process*. Guide, AIA, 2012.

Al-Tamimi, Nedhal Ahmed, Sharifah Fairuz Syed Fadzil, and Wan Mariah Wan Harun. "The Effects of Orientation, Ventilation and Varied WWR on the Thermal Performance of Residential Rooms in the Tropics." *Journal of Sustainable Development*, 2011.

Alter, Lloyd. "Why Architects Shouldn't Build Condos out of Glass and People Shouldn't Buy Them." *Tree Hugger*, 2011.

Anderson, Kjell. *Design Energy Simulation for Architects, Guide to 3D Graphics*. New York: Routledge, 2014.

Arch Daily. "The Met/WOHA." November 11, 2015.

Architects, American Institutes of. *An Architect's Guide to Integrating Energy Modeling in the Design Process*. 2012.

ASHRAE. *ASHRAE Standard 55 Thermal Environmental Conditions for Human Occupancy*. Atlanta: American Society of Heating, Refrigerating and Air-Conditioning Engineers, Inc., 2013.

—. *ASHRAE Standard 62.1 Ventilation for Acceptable Indoor Air Quality*. Atlanta: American Society of Heating, Refrigerating and Air-Conditioning Engineers, Inc., 2013.

Auckland, North Shore City Council. *Good Solutions Guide for Apartments*. Guide, Auckland: Auckland: North Shore City Council, 2007.

Aynsley, Richard. "Circulating Fans for Summer and Winter Comfort and Indoor Energy Efficiency." *Environment Design Guide*, 2007.

Baker, Nick. "Natural Ventilation: Cross Ventilation." *Royal Institute of British Architects*, 2014.

Beizae, A., S.K. Firth, K. Vadodaria, and D. Loveday. "Assessing the Ability of PMV Model in Predicting Thermal Sensation in Naturally Ventilated Buildings in the UK." *7th Windsor*

Conference: *The Changing Context of Comfort in an Unpredictable World*. Windsor: London: Network for Comfort and Energy Use in Buildings, 2012.

Bezemer, Victoria. *Can Vernacular Architecture in the Tropics Assist with Modern Passive Ventilation Design in Domestic Buildings?* 2008.

Brager, G.S., and R.J. de Dear. "Thermal Adaptation in the Built Environment: A Literature Review." *Energy and Buildings*, 1998: 27, 83-96.

Brager, Gail, and Richard de Dear. *Climate, Comfort, and Natural Ventilation: A New Adaptive Comfort Standard for ASHRAE Standard 55*. Paper, Center for Environmental Design Research: Center for the Built Environment, 2001.

Britannica, Encyclopaedia. *Acclimatization*. 2015.
<http://www.britannica.com/EBchecked/topic/2983/acclimatization> (accessed 2015).

Chenvidyakarn, T. "Passive Design Techniques for Thermal Comfort in Hot and Humid Climates." 2007.

Cho, G.Y., C.R. Kim, S.W. Lee, C.S. Park, M.S. Yeo, and K.W. Kim. *An Analysis of the Envelope to Improve Environmental Performance of High Rise Residential Buildings*. Seoul: Proceeding of Clima, 2007.

Creamer, Beverly. "Kaka'ako's Building Boom." *Hawaii Business*, January 2012.

Daniels, Klaus. *The Technology of Ecological Building: Basic Principles and Measures, Examples and Ideas*. Basel: Birkhauser Verlag, 1997.

DBEDT. *In Field Guide for Energy Performance, Comfort, and Value in Hawaii Homes*. Guidelines, Honolulu: Department of Business, Economic Development & Tourism Energy, Resources & Technology Division, 2001.

de Dear, Richard, and Gail Brager. "Thermal Comfort in Naturally Ventilated Buildings: Revisions to ASHRAE Standard 55." *Energy and Buildings*, 2002: 549-561.

de Dear, Richard, Christhina Cândido, Roberto Lamberts, and Leonardo Bittencourt. "Cooling Exposure in Hot Humid Climates: Are Occupants "Addicted"?" *Architectural Science Review*, 2010: 59-64.

- EPA. *Buildings and their Impact on the Environment: A Statistical Summary*. Statistics, Environmental Protection Agency, 2009.
- Essays, UK. "Unite Habitation Marseilles By Le Corbusier Cultural Studies Essay." *UK Essay*, 2013.
- Fanger, P.O., and J. Toftum. "Extension of the PMV Model to Non-Air-Conditioned Buildings in Warm Climates." *Energy and Buildings* (Energy and Buildings), 2002: 34, 533-536.
- Fearson, Amy. "Brutalist Buildings: Unité d'Habitation, Marseilles by Le Corbusier." *De Zeen Magainze*, 2014.
- Feustel, Helmut, and Richard Diamond. *Air Flow Distribution in a High Rise Residential Building*. Berkeley: Lawrence Berkeley National Laboratory, 1998.
- Givoni, B. *Climate Considerations in Building and Urban Design*. John Wiley & Sons, 1998.
- Glancy, Johnathan. "Le Corbusier's Unité: Is it a modern classic?" *BBC: Culture*, 2013.
- Gomaa, Bakr. *Innovation in Natural Ventilation in Building's Design and Application*. Alexandria: Arab Academy for Science and Technology, 2013.
- Grondzik, Walter, Alison Kwok, Benjamin Stein, and John Reynolds. *Mechanical and Electrical Equipment for Buildings, 11th Edition*. New Jersey: John Wiley & Sons, 2010.
- Heidari, Shahin, and Steve Sharples. "A Comparative Analysis of Short-term and Long-term Thermal Comfort Surveys in Iran." *Energy and Buildings*, 2002.
- Hellwig, R.T., S. Brasche, W. Bischof. *Thermal Comfort in Offices - Natural Ventilation vs. Air Conditioning*. Jena, Germany: Friedrich-Schiller-University Jena, Dept. Indoor Climatology, 2013.
- Hwang, Ruey-Lung, Ming-jen Cheng, Tzu-Ping Lin, and Ming-Chin Ho. "Thermal Perceptions, General Adaptation Methods and Occupant's Idea about the Trade-Off between Thermal Comfort and Energy Saving in Hot-Humid Regions." *Building and Environment*, 2009: 1128-1134.

IBC. *International Building Code*. Code, International Code Council, 2009.

Instruments, National. "National Instruments." *Control Global*. 2015.

http://www.controlglobal.com/assets/vendornews/VendorNotes/090212_NI_CEMS.pdf
(accessed 2015).

Jaakkola, JJ, and P Miettinen. "Tpe of Ventilation System in Office Buildings and Sick Building Syndrome." *Am J Epidemiol*, 1995.

Jatupatwarangkul, Sanphawat. *Bangkok - Pursuit of Net Zero Energy Design Testing the Potential for a Prototype High-Rise Residential Mixed-Used Building Design*. Doctorate Project, Honolulu: Univeristy of Hawaii at Manoa, School of Architecture, 2012.

Kim, Cho Rong, Ga Young Cho, Sun Woo Lee, Souk Myoung Yeo, and Kwang Woo Kim. *Opening Design to Improve the Natural Ventilation Performance of High-Rise Residential Buildings*. Seoul, 2008.

Kleiven, Tommy. *Natural Ventilation in Buildings: Architectural Concepts, Consequences and Possibilities*. Thesis, Norwegian University of Science and Technology, 2003.

Levine, Mark, and Diana Ürge-Vorsatz. *Chapter 6: Residential and Commercial Buildings*. Assessment, Intergovernmental Panel on Climate Change, 2014.

Linden van der, Willemijne, Marcel Loomans, and Jan Hensen. *Adaptive Thermal Comfort Explained by PMV*. Eindhoven University of Technology, Department of Architecture Building and Planning, 2008.

Linden, Willemijne van der, Marcel Loomans, and Jan Hensen. *Adaptive Thermal Comfort Explained by PMV*. Research Report, Eindhoven University of Technology, Department of Architecture Building and Planning, Unit Building Physics and Systems, The Netherlands, 2008.

Ling, Chia Sok, Mohd. Hamdan Ahmad, and Dilshan Remaz Ossen. "The Effect of Geometric Shape and Building Orientation on Minimizing Solar Isolation on High-Rise Buildings in Hot Humid Climate." *Journal of Construction in Developing Countries*, 2007.

Meguro, Wendy. *Beyond Blue and Red Arrows: Optimizing Natural Ventilation in Large Buildings*. Thesis, Massachusetts: Massachusetts Institute of Technology, 2005.

Nicol, F. "Adaptive Thermal Comfort Standards in the Hot-Humid Tropic." *Energy and Buildings*, 2004.

NOAA, National Oceanic and Atmospheric Administration. *Climate of Hawaii*. 2007. http://www.prh.noaa.gov/hnl/pages/climate_summary.php (accessed 2015).

Norberg-Schulz, Christian. *Intentions in Architecture Norberg*. Massachusetts: MIT Press, 1968.

Rutes, Walter, Richard Penner, and Lawrence Adams. *Challenges in Hotel Design: Planning the Guest Room Floor*. Research, Sage Publication, 2001.

Sekhar, SC. "Thermal Comfort in Air-Conditioned Buildings in Hot and Humid Climates - Why are we not getting it right?" 2015.

Shear, Timothy. "High Cost, Oil-fired Generation Creates Potential for Shift in Hawaiian Electric Sources." *U.S. Energy Administration*. February 1, 2014. <http://www.eia.gov/todayinenergy/detail.cfm?id=15091> (accessed 2015).

Shimaogawa, Duane. "Hawaii Construction Report Highlights Demand for More Housing." *Pacific Business News*, February 20, 2014.

Simons, Barbara, Christian Koranteng, Emmanuel Adinyira, and Joshua Ayarkwa. "An Assessment of Thermal Comfort in Multi-Storey Office Buildings in Ghana." *Journal of Building Construction and Planning Research*, 2014: 30-38.

State, Hawaii. *Hawaii Ambient Air Quality*. Honolulu: State of Hawaii: Department of Health, 2015.

Station, Honolulu International Airport Weather. Weather Data File, Honolulu.

Straube, John. "Can Highly Glazed Building Facades Be Green?" *Building Science Corporation*. 2011. <http://www.buildingscience.com/documents/insights/bsi-006-can-fully-glazed-curtainwalls-be-green?topic=resources/low-energy-bldgs> (accessed 2015).

Tropics, State of the. "State of the Tropics 2014 Report." 2014.

Turner, Scott, and Rupert Soar. *Beyond Biomimicry: What Termites can tell Us About Realizing Living Building*. PhD Diss., SUNY College of Environmental Science and Forestry, 2008.

Twinn, Chris. "Cooling Customers: Innovations in Office Buildings." *Architecture Today*, 2011.

Waewsak, Jompob, Joseph Khedari, Rangsit Sarachitti, and Jongjit Hirunlabh. "Direction of Velocity of Surface Wind in Bangkok." *Building Scientific Research Center Thammasatl Int.*, 2002.

Wong, Grace. "Vertical Cities as a solution for Land Scarcity: The Tallest Public Housing Development in Singapore." *Urban Design International*, 2004.

Yeang, Ken, interview by Far Eastern Review. *AC Cannot be Completely Abandoned in the Tropics but Passive Techniques can Reduce the Need for Mechanical Cooling Devices* (2008).

—. *The Skyscrapers: Bioclimatically Considered*. London: Academy Group Ltd., 1996.

Yuan, Lim Jee. *The Maylay House: Rediscovering Malaysia's Indigenous Shelter System*. Pinang: Institut Masyarakat, 1987.